

A1

ವರ್ಷನ್ ಕೋಡ್

21UGE

ಗರಿಷ್ಠ ಅಂಕಗಳು : 60

ಒಟ್ಟು ಪ್ರಶ್ನೆಗಳು : 60

ಒಟ್ಟು ಅವಧಿ : 80 ನಿಮಿಷಗಳು

ಉತ್ತರಿಸಲು ಇರುವ ಗರಿಷ್ಠ ಅವಧಿ : 70 ನಿಮಿಷಗಳು

ಸಮಯ : ಮ. 02.30 ರಿಂದ 03.50 ರ ವರೆಗೆ

ನಿಮ್ಮ ಸಿಇಟಿ ಸಂಖ್ಯೆಯನ್ನು ಬರೆಯಿರಿ

ಕ್ರಮ

ಸಂಖ್ಯೆ :

770353

ವಿಷಯ

ಸಂಕೇತ

2C0829K

ಮಾಡಿ

1. ಕೊಠಡಿ ಮೇಲ್ವಿಚಾರಕರಿಂದ ಈ ಪ್ರಶ್ನೆ ಪತ್ರಿಕೆಯನ್ನು ನಿಮಗೆ ಮ. 2.30 ಆದ ನಂತರ ಕೊಡಲಾಗಿರುತ್ತದೆ.
2. ಅಭ್ಯರ್ಥಿಗಳು ಸಿಇಟಿ ಸಂಖ್ಯೆಯನ್ನು ಓ.ಎಂ.ಆರ್. ಉತ್ತರ ಪತ್ರಿಕೆಯಲ್ಲಿ ಬರೆದು ಅದಕ್ಕೆ ಸಂಬಂಧಿಸಿದ ವೃತ್ತಗಳನ್ನು ಸಂಪೂರ್ಣವಾಗಿ ತುಂಬಿದ್ದೀರೆಂದು ಖಾತ್ರಿಪಡಿಸಿಕೊಳ್ಳಿ.
3. ಪ್ರಶ್ನೆ ಪತ್ರಿಕೆಯ ವರ್ಷನ್ ಕೋಡ್ ಅನ್ನು ಓ.ಎಂ.ಆರ್. ಉತ್ತರ ಪತ್ರಿಕೆಯಲ್ಲಿ ಬರೆದು ಅದಕ್ಕೆ ಸಂಬಂಧಿಸಿದ ವೃತ್ತಗಳನ್ನು ಸಂಪೂರ್ಣವಾಗಿ ತುಂಬಬೇಕು.
4. ಪ್ರಶ್ನೆ ಪತ್ರಿಕೆಯ ವರ್ಷನ್ ಕೋಡ್ ಮತ್ತು ಕ್ರಮ ಸಂಖ್ಯೆಯನ್ನು ನಾಮಿನಲ್ ರೋಲ್‌ನಲ್ಲಿ ತಪ್ಪಿಲ್ಲದೆ ಬರೆಯಬೇಕು.
5. ಓ.ಎಂ.ಆರ್. ಉತ್ತರ ಪತ್ರಿಕೆಯ ಕೆಳಭಾಗದ ನಿಗದಿತ ಜಾಗದಲ್ಲಿ ಪೂರ್ಣ ಸಹಿ ಮಾಡಬೇಕು.

ಮಾಡಬೇಡಿ

1. ಓ.ಎಂ.ಆರ್. ಉತ್ತರ ಪತ್ರಿಕೆಯಲ್ಲಿ ಮುದ್ರಿತವಾಗಿರುವ ಟೈಮಿಂಗ್ ಮಾರ್ಕನ್ನು ತಿದ್ದಬಾರದು / ಹಾಳುಮಾಡಬಾರದು / ಅಳಿಸಬಾರದು.
2. ಮೂರನೇ ಬೆಲ್ ಮ. 2.40 ಕ್ಕೆ ಆಗುತ್ತದೆ. ಅಲ್ಲಿಯವರೆಗೂ,
 - ಪ್ರಶ್ನೆ ಪತ್ರಿಕೆಯ ಬಲಭಾಗದಲ್ಲಿರುವ ಸೀಲ್ ಅನ್ನು ತೆಗೆಯಬಾರದು.
 - ಪ್ರಶ್ನೆ ಪತ್ರಿಕೆಯ ಒಳಗಡೆ ಇರುವ ಪ್ರಶ್ನೆಗಳನ್ನು ನೋಡಲು ಪ್ರಯತ್ನಿಸಬಾರದು ಮತ್ತು ಓ.ಎಂ.ಆರ್. ಉತ್ತರ ಪತ್ರಿಕೆಯಲ್ಲಿ ಉತ್ತರಿಸಲು ಪ್ರಾರಂಭಿಸಬಾರದು.

ಅಭ್ಯರ್ಥಿಗಳಿಗೆ ಮುಖ್ಯ ಸೂಚನೆಗಳು

1. ಪ್ರಶ್ನೆಗಳಲ್ಲಿ ಬಳಸಿರುವ signs and symbols ಗಳನ್ನು, ಬೇರೆ ರೀತಿಯಲ್ಲಿ ಹೇಳದ ಹೊರತು, ನಿಗದಿತ ಪಠ್ಯಪುಸ್ತಕದಲ್ಲಿನ ಅರ್ಥವನ್ನು ಪರಿಗಣಿಸಬೇಕು.
2. ಪ್ರಶ್ನೆ ಪತ್ರಿಕೆಯಲ್ಲಿ ಒಟ್ಟು 60 ಪ್ರಶ್ನೆಗಳಿದ್ದು, ಪ್ರತಿ ಪ್ರಶ್ನೆಗೂ 4 ಬಹು ಆಯ್ಕೆ ಉತ್ತರಗಳು ಇರುತ್ತವೆ. ಪ್ರತಿ ಪ್ರಶ್ನೆಯ ಕೆಳಗೆ ಕೊಟ್ಟಿರುವ ನಾಲ್ಕು ಬಹು ಆಯ್ಕೆಯ ಉತ್ತರಗಳಲ್ಲಿ ಸರಿಯಾದ ಒಂದು ಉತ್ತರವನ್ನು ಆಯ್ಕೆ ಮಾಡಿ.
3. ಮೂರನೇ ಬೆಲ್ ಅಂದರೆ ಮ. 2.40 ರ ನಂತರ ಪ್ರಶ್ನೆ ಪತ್ರಿಕೆಯ ಬಲಭಾಗದಲ್ಲಿರುವ ಸೀಲ್ ತೆಗೆದು ಈ ಪ್ರಶ್ನೆ ಪತ್ರಿಕೆಯಲ್ಲಿ ಯಾವುದೇ ಪುಟಗಳು ಮುದ್ರಿತವಾಗಿಲ್ಲದೇ ಇರುವುದು ಕಂಡು ಬಂದಲ್ಲಿ ಅಥವಾ ಹರಿದು ಹೋಗಿದ್ದಲ್ಲಿ ಅಥವಾ ಯಾವುದೇ ಐಟಂಗಳು ಬಿಟ್ಟುಹೋಗಿದ್ದಲ್ಲಿ ಎಂಬುದನ್ನು ಖಚಿತಪಡಿಸಿಕೊಂಡು, ಈ ರೀತಿ ಆಗಿದ್ದರೆ ಪ್ರಶ್ನೆಪತ್ರಿಕೆಯನ್ನು ಬದಲಾಯಿಸಿ ಕೊಳ್ಳುವುದು ನಂತರ ಓ.ಎಂ.ಆರ್. ಉತ್ತರ ಪತ್ರಿಕೆಯಲ್ಲಿ ಉತ್ತರಿಸಲು ಪ್ರಾರಂಭಿಸುವುದು.
4. ಪ್ರಶ್ನೆ ಪತ್ರಿಕೆಯಲ್ಲಿನ ಪ್ರಶ್ನೆಗೆ ಅನುಗುಣವಾಗಿರುವ ಸರಿ ಉತ್ತರವನ್ನು ಓ.ಎಂ.ಆರ್. ಉತ್ತರ ಪತ್ರಿಕೆಯಲ್ಲಿ ಅದೇ ಕ್ರಮ ಸಂಖ್ಯೆಯ ಮುಂದೆ ನೀಡಿರುವ ಸಂಬಂಧಿಸಿದ ವೃತ್ತವನ್ನು ನೀಲಿ ಅಥವಾ ಕಪ್ಪು ಶಾಯಿಯ ಬಾಲ್ ಪಾಯಿಂಟ್ ಪೆನ್‌ನಿಂದ ಸಂಪೂರ್ಣ ತುಂಬುವುದು.

ಸರಿಯಾದ ಕ್ರಮ	ತಪ್ಪು ಕ್ರಮಗಳು WRONG METHODS								
CORRECT METHOD	<input checked="" type="checkbox"/>	<input type="checkbox"/>	<input type="checkbox"/>	<input type="checkbox"/>	<input type="checkbox"/>	<input type="checkbox"/>	<input type="checkbox"/>	<input type="checkbox"/>	<input type="checkbox"/>
<input type="checkbox"/>	<input type="checkbox"/>	<input type="checkbox"/>	<input type="checkbox"/>	<input type="checkbox"/>	<input type="checkbox"/>	<input type="checkbox"/>	<input type="checkbox"/>	<input type="checkbox"/>	<input type="checkbox"/>

5. ಈ ಓ.ಎಂ.ಆರ್. ಉತ್ತರ ಪತ್ರಿಕೆಯನ್ನು ಸ್ಕ್ಯಾನ್ ಮಾಡುವ ಸ್ಕ್ಯಾನರ್ ಬಹಳ ಸೂಕ್ಷ್ಮವಾಗಿದ್ದು ಸಣ್ಣ ಗುರುತನ್ನು ಸಹ ದಾಖಲಿಸುತ್ತದೆ. ಆದ್ದರಿಂದ ಓ.ಎಂ.ಆರ್. ಉತ್ತರ ಪತ್ರಿಕೆಯಲ್ಲಿ ಉತ್ತರಿಸುವಾಗ ಎಚ್ಚರಿಕೆ ವಹಿಸಿ.
6. ಪ್ರಶ್ನೆ ಪತ್ರಿಕೆಯಲ್ಲಿ ಕೊಟ್ಟಿರುವ ಖಾಲಿ ಜಾಗವನ್ನು ರಫ್ ಕೆಲಸಕ್ಕೆ ಉಪಯೋಗಿಸಿ. ಓ.ಎಂ.ಆರ್. ಉತ್ತರ ಪತ್ರಿಕೆಯನ್ನು ಇದಕ್ಕೆ ಉಪಯೋಗಿಸಬೇಡಿ.
7. ಕೊನೆಯ ಬೆಲ್ ಅಂದರೆ ಮ. 3.50 ಆದ ನಂತರ ಉತ್ತರಿಸುವುದನ್ನು ನಿಲ್ಲಿಸಿ.
8. ಓ.ಎಂ.ಆರ್. ಉತ್ತರ ಪತ್ರಿಕೆಯನ್ನು ಕೊಠಡಿ ಮೇಲ್ವಿಚಾರಕರಿಗೆ ಯಥಾಸ್ಥಿತಿಯಲ್ಲಿ ನೀಡಿರಿ.
9. ಕೊಠಡಿ ಮೇಲ್ವಿಚಾರಕರು ಮೇಲ್ಭಾಗದ ಹಾಳೆಯನ್ನು ಪ್ರತ್ಯೇಕಿಸಿ (ಕಚೇರಿ ಪ್ರತಿ) ತನ್ನ ವಶದಲ್ಲಿ ಇಟ್ಟುಕೊಂಡು ತಳಬದಿಯ ಯಥಾಪ್ರತಿಯನ್ನು (ಅಭ್ಯರ್ಥಿಯ ಪ್ರತಿ) ಅಭ್ಯರ್ಥಿಗಳಿಗೆ ಕೊಡುತ್ತಾರೆ.

ಸೂಚನೆ: ಕನ್ನಡ ಆವೃತ್ತಿಯ ಪ್ರಶ್ನೆಗಳಲ್ಲಿ ಉತ್ತರಿಸುವ ಅಭ್ಯರ್ಥಿಗಳಿಗೆ ಕನ್ನಡದಲ್ಲಿ ಮುದ್ರಿತವಾಗಿರುವ ಪ್ರಶ್ನೆಗಳ ಬಗ್ಗೆ ಏನಾದರೂ ಸಂದೇಹವಿದ್ದಲ್ಲಿ ಇಂಗ್ಲೀಷ್ ಆವೃತ್ತಿಯ ಪ್ರಶ್ನೆಪತ್ರಿಕೆಯನ್ನು ನೋಡಬಹುದು. ಏನಾದರೂ ವ್ಯತ್ಯಾಸ ಕಂಡುಬಂದಲ್ಲಿ ಇಂಗ್ಲೀಷ್ ಆವೃತ್ತಿಯನ್ನು ಅಂತಿಮ ಎಂದು ಪರಿಗಣಿಸಲಾಗುವುದು.

C

270328

DO NOT WRITE HERE

A1

VERSION CODE

21UGE

Maximum Marks : 60

Total No. of Questions : 60

Total Duration : 80 Minutes

Maximum Time for Answering : 70 Minutes

Time : 02.30 pm to 03.50 pm

MENTION YOUR CET NUMBER

Serial
Number :

Subject
Code

2C0829K

Dos:

1. This question booklet is issued to you by the room invigilator **after 2.30 pm**.
2. Check whether the CET Number has been entered and shaded in the respective circles on the OMR answer sheet.
3. The version code of this question booklet should be entered on the OMR answer sheet and the respective circles should also be shaded completely.
4. The Version Code and Serial Number of this question booklet should be entered on the Nominal Roll without any mistakes.
5. Compulsorily sign at the bottom portion of the OMR answer sheet in the space provided.

DON'Ts:

1. **THE TIMING AND MARKS PRINTED ON THE OMR ANSWER SHEET SHOULD NOT BE DAMAGED MUTILATED / SPOILED.**
2. The **3rd Bell rings at 2.40 pm, till then**
 - Do not remove the seal present on the right hand side of this question booklet.
 - Do not look inside this question booklet or start answering on the OMR answer sheet.

IMPORTANT INSTRUCTIONS TO CANDIDATES

1. In case of usage of signs and symbols in the questions, the regular textbook connotation should be considered unless stated otherwise.
2. This question booklet contains 60 questions and each question will have one statement and four different options / responses & out of which you have to choose one correct answer.
3. After the **3rd Bell rings at 2.40 pm**, remove the paper seal of this question booklet and check that this booklet does not have any unprinted or torn or missing pages or items etc., if so, get it replaced by complete test booklet. Read each item and start answering on the OMR answer sheet.
4. Completely **darken / shade** the relevant circle with a **blue or black ink ballpoint pen against the question number on the OMR answer sheet.**

ಸರಿಯಾದ ಕ್ರಮ CORRECT METHOD	ತಪ್ಪು ಕ್ರಮಗಳು WRONG METHODS
<input type="radio"/> A <input checked="" type="radio"/> B <input type="radio"/> C <input type="radio"/> D	<input checked="" type="radio"/> X <input type="radio"/> B <input type="radio"/> C <input type="radio"/> D <input type="radio"/> A <input type="radio"/> B <input type="radio"/> C <input checked="" type="radio"/> D <input type="radio"/> A <input checked="" type="radio"/> B <input checked="" type="radio"/> C <input type="radio"/> D
<input type="radio"/> A <input checked="" type="radio"/> B <input type="radio"/> C <input type="radio"/> D	<input checked="" type="radio"/> A <input type="radio"/> B <input type="radio"/> C <input type="radio"/> D <input type="radio"/> A <input checked="" type="radio"/> B <input type="radio"/> C <input type="radio"/> D

5. Please note that even a minute unintended ink dot on the OMR answer sheet will also be recognized and recorded by the scanner. Therefore, avoid multiple markings of any kind on the OMR answer sheet.
6. Use the space provided on each page of the question booklet for Rough Work. Do not use the OMR answer sheet for the same.
7. **Last Bell will ring at 3.50 pm**, stop writing on the OMR answer sheet.
8. Hand over the **OMR answer sheet** to the room invigilator as it is.
9. After separating the top sheet (Office copy), the invigilator will return the bottom sheet replica (Candidate copy) to you.

NOTE: In case of any discrepancy between English and Kannada Versions, the English version will be taken as final.

CHEMISTRY

In Chrysoberyl, a compound containing Beryllium, Aluminium and oxygen, oxide ions form cubic close packed structure. Aluminium ions occupy $1/4$ th of tetrahedral voids and Beryllium ions occupy $1/4$ th of octahedral voids. The formula of the compound is

- (A) BeAlO_4 (B) BeAl_2O_4
(C) Be_2AlO_2 (D) BeAlO_2

The correct statement regarding defects in solids is

- (A) Frenkel defect is a vacancy defect
(B) Schottky defect is a dislocation defect
(C) Trapping of an electron in the lattices leads to the formation of F-centre
(D) Schottky defect has no effect on density.

A metal crystallises in BCC lattice with unit cell edge length of 300 pm and density 6.15 g cm^{-3} .

The molar mass of the metal is

- (A) 50 g mol^{-1} (B) 60 g mol^{-1}
(C) 40 g mol^{-1} (D) 70 g mol^{-1}

Henry's law constant for the solubility of N_2 gas in water at 298 K is $1.0 \times 10^5 \text{ atm}$. The mole fraction of N_2 in air is 0.8. The number of moles of N_2 from air dissolved in 10 moles of water at 298 K and 5 atm pressure is

- (A) 4.0×10^{-4} (B) 4.0×10^{-5}
(C) 5.0×10^{-4} (D) 4.0×10^{-6}

A pure compound contains 2.4 g of C, 1.2×10^{23} atoms of H, 0.2 moles of oxygen atoms. Its empirical formula is

- (A) C_2HO (B) $\text{C}_2\text{H}_2\text{O}_2$
(C) CH_2O (D) CHO

SPACE FOR ROUGH WORK

ರಸಾಯನಶಾಸ್ತ್ರ

1. ಕ್ರೋಮೀಯಂ ಎಂಬ ಸಂಯುಕ್ತದಲ್ಲಿ ಬೆರಲಿಯಂ, ಅಲ್ಯೂಮಿನಿಯಂ ಮತ್ತು ಆಕ್ಸಿಜನ್ ಇದ್ದು, ಆಕ್ಸಿಡ್ ಆಯಾನು ಘನ ನಿಕಟಜೋಡಣೆಯನ್ನು ಉಂಟು ಮಾಡುತ್ತದೆ. ಅಲ್ಯೂಮಿನಿಯಂ ಆಯಾನು ಚತುರ್ಮುಖೀಯ ನಿರರ್ಥಕದಲ್ಲಿ 1/4 ರಷ್ಟು ಆಕ್ರಮಿಸುತ್ತದೆ. ಬೆರಲಿಯಂ ಆಯಾನು ಅಷ್ಟಮುಖೀಯ ನಿರರ್ಥಕದಲ್ಲಿನ 1/4 ರಷ್ಟು ಆಕ್ರಮಿಸುತ್ತದೆ. ಈ ಸಂಯುಕ್ತದ ಅಣು ಸೂತ್ರವು

(A) BeAlO_4	(B) BeAl_2O_4
(C) Be_2AlO_2	(D) BeAlO_2

2. ಘನ ವಸ್ತು ಗಳಲ್ಲಿನ ನ್ಯೂನತೆಯ ಬಗ್ಗೆ ಸರಿಯಾದ ಹೇಳಿಕೆಯು ಇದಾಗಿದೆ .

(A) ಫ್ರೆಂಕಲ್ ನ್ಯೂನತೆಯು ಖಾಲಿ ನ್ಯೂನತೆಯಾಗಿದೆ.	(B) ಸ್ಕಾಟ್ಲಿ ನ್ಯೂನತೆಯು ಸ್ಥಳಾಂತರಿಸುವ ನ್ಯೂನತೆಯಾಗಿದೆ
(C) ಎಲೆಕ್ಟ್ರಾನ್ ಜೌಲರಿಯಲ್ಲಿ ಆಕ್ರಮಿಸಿಕೊಂಡು F-ಕೇಂದ್ರವೊಂದು ಉಂಟಾಗುತ್ತದೆ.	(D) ಸ್ಕಾಟ್ಲಿ ನ್ಯೂನತೆಯು ಸಾಂದ್ರತೆಯ ಮೇಲೆ ಯಾವ ಪರಿಣಾಮ ಬೀರುವುದಿಲ್ಲ.

3. 300 pm ಅಂಚಿನ ಉದ್ದವಿರುವ ಮತ್ತು 6.15 g cm^{-3} . ಸಾಂದ್ರತೆಯುಳ್ಳ ಲೋಹವೊಂದು BCC ಜೌಲರಿಯಲ್ಲಿ ಹರಳಾಗುತ್ತದೆ. ಲೋಹದ ಮೋಲಾರ್ ದ್ರವ್ಯರಾಶಿಯು ಇದಾಗಿದೆ.

(A) 50 g mol^{-1}	(B) 60 g mol^{-1}
(C) 40 g mol^{-1}	(D) 70 g mol^{-1}

4. ನೀರಿನಲ್ಲಿ ನೈಟ್ರೋಜನ್ ಅನಿಲದ ವಿಲೀನತೆಗೆ ಹೆನ್ರಿ ಸ್ಥಿರಾಂಕವು 298 K ನಲ್ಲಿ $1.0 \times 10^5 \text{ atm}$ ಆಗಿದೆ. ಗಾಳಿಯಲ್ಲಿ ನೈಟ್ರೋಜನ್‌ನ ಮೋಲ್ ಭಿನ್ನಾಂಶವು 0.8 ಆಗಿದೆ. 298K ಮತ್ತು 5 atm ಒತ್ತಡದಲ್ಲಿ 10 ಮೋಲ್ ನೀರಿನಲ್ಲಿ ಗಾಳಿಯಿಂದ ವಿಲೀನಗೊಂಡ N_2 ನ ಮೋಲ್‌ಗಳ ಸಂಖ್ಯೆಯು

(A) 4.0×10^{-4}	(B) 4.0×10^{-5}
(C) 5.0×10^{-4}	(D) 4.0×10^{-6}

5. ಶುದ್ಧ ಸಂಯುಕ್ತವೊಂದರಲ್ಲಿ ಶೇ. 2.4 ರಷ್ಟು C , 1.2×10^{23} ಪರಮಾಣುಗಳಷ್ಟು H ಮತ್ತು 0.2 ಮೋಲ್‌ಗಳಷ್ಟು ಆಕ್ಸಿಜನ್ ಅಣುಗಳನ್ನು ಹೊಂದಿರುತ್ತದೆ. ಇದರ ಸಂಯೋಜನ ಸೂತ್ರವು :

(A) C_2HO	(B) $\text{C}_2\text{H}_2\text{O}_2$
(C) CH_2O	(D) CHO

SPACE FOR ROUGH WORK

6. Choose the correct statement
- (A) K_H value is same for a gas in any solvent
 (B) Higher the K_H value more the solubility of gas
 (C) K_H value increases on increasing the temperature of the solution
 (D) Easily liquefiable gases usually has lesser K_H values
7. The K_H value (K bar) of Argon (I), Carbondioxide (II) formuldehyde (III) and methane (IV) are respectively 40.3, 1.67, 1.83×10^{-5} and 0.413 at 298 K. The increasing order of solubility of gas in liquid is
- (A) I < II < IV < III
 (B) III < IV < II < I
 (C) I < III < II < IV
 (D) I < IV < II < III
8. The vapour pressure of pure liquids A and B are 450 and 700 mm of Hg at 350 K respectively. If the total vapour pressure of the mixture is 600 mm of Hg, the composition of the mixture in the solution is
- (A) $x_A = 0.4, x_B = 0.6$
 (B) $x_A = 0.6, x_B = 0.4$
 (C) $x_A = 0.3, x_B = 0.7$
 (D) $x_A = 0.7, x_B = 0.3$
9. Consider the following electrodes
- P = Zn^{2+} (0.0001 M)/Zn Q = Zn^{2+} (0.1 M)/Zn
 R = Zn^{2+} (0.01 M)/Zn S = Zn^{2+} (0.001 M)/Zn
 $E^\circ Zn/Zn^{2+} = -0.76$ V Electrode potentials of the above electrodes in volts are in the order
- (A) P > S > R > Q
 (B) S > R > Q > P
 (C) Q > R > S > P
 (D) P > Q > R > S
10. The number of angular and radial nodes in 3p orbital respectively are
- (A) 3, 1
 (B) 1, 1
 (C) 2, 1
 (D) 2, 3
11. The resistance of 0.01 m KCl solution at 298 K is 1500 Ω . If the conductivity of 0.01 m KCl solution at 298 K is 0.146×10^{-3} S cm^{-1} . The cell constant of the conductivity cell in cm^{-1} is
- (A) 0.219
 (B) 0.291
 (C) 0.301
 (D) 0.194

SPACE FOR ROUGH WORK

6. ಸರಿಯಾದ ಹೇಳಿಕೆಯನ್ನು ಆಯ್ಕೆ ಮಾಡಿ
 (A) ಯಾವುದೇ ದ್ರಾವಣದಲ್ಲಿ ಒಂದು ಅನಿಲದ K_H ಮೌಲ್ಯವು ಒಂದೇ ಆಗಿದೆ.
 (B) ಒಂದು ಅನಿಲದ K_H ಮೌಲ್ಯವು ಅಧಿಕವಾಗಿದ್ದರೆ ಅದರ ವಿಲೀನತೆ ಹೆಚ್ಚಾಗಿರುತ್ತದೆ.
 (C) ದ್ರಾವಣದ ತಾಪಮಾನ ಹೆಚ್ಚಾದಂತೆ K_H ಮೌಲ್ಯವು ಹೆಚ್ಚಾಗುತ್ತದೆ
 (D) ಸರಾಗವಾಗಿ ದ್ರವೀಕರಣಗೊಳಿಸಬಲ್ಲ ಅನಿಲಗಳು ಸಾಮಾನ್ಯವಾಗಿ ಕಡಿಮೆ K_H ಮೌಲ್ಯ ಹೊಂದಿದೆ.
7. ಆರ್ಗನ್ (I), ಕಾರ್ಬನ್ ಡೈ ಆಕ್ಸೈಡ್ (II) ಫಾರ್ಮಿಕ್ ಆಮ್ಲ (III) ಮತ್ತು ಮೀಥೇನ್ (IV) ಗಳಿಗೆ 298 K ನಲ್ಲಿ K_H (K bar) ಮೌಲ್ಯವು ಕ್ರಮವಾಗಿ 40.3, 1.67, 1.83×10^{-5} ಮತ್ತು 0.413 ಆಗಿರುತ್ತದೆ. ಅನಿಲವು ದ್ರವದಲ್ಲಿ ವಿಲೀನತೆಗೊಳ್ಳುವ ಏರಿಕೆ ಕ್ರಮವು ಇದಾಗಿದೆ.
 (A) I < II < IV < III
 (B) III < IV < II < I
 (C) I < III < II < IV
 (D) I < IV < II < III
8. 350K ನಲ್ಲಿ A ಮತ್ತು B ಶುದ್ಧ ದ್ರಾವಣಗಳ ಆವಿ ಒತ್ತಡವು ಕ್ರಮವಾಗಿ 450 ಮತ್ತು 700 mm of Hg ಆಗಿರುತ್ತದೆ. ಈ ಮಿಶ್ರಣದ ಒಟ್ಟು ಆವಿ ಒತ್ತಡವು 600 mm of Hg ಆದರೆ, ದ್ರಾವಣದಲ್ಲಿ ಮಿಶ್ರಣದ ಸಂಯೋಜನೆಯು ಇದಾಗಿದೆ.
 (A) $x_A = 0.4, x_B = 0.6$
 (B) $x_A = 0.6, x_B = 0.4$
 (C) $x_A = 0.3, x_B = 0.7$
 (D) $x_A = 0.7, x_B = 0.3$
9. ಈ ಕೆಳಕಂಡ ವಿದ್ಯುದ್ರಾಶಯಗಳನ್ನು ಪರಿಗಣಿಸಿ
 $P = Zn^{2+} (0.0001 M)/Zn$ $Q = Zn^{2+} (0.1 M)/Zn$
 $R = Zn^{2+} (0.01 M)/Zn$ $S = Zn^{2+} (0.001 M)/Zn$
 $E^\circ Zn/Zn^{2+} = -0.76 V$. ಈ ಮೇಲಿನ ವಿದ್ಯುದ್ರಾಶಯಗಳಿಗೆ ವೋಲ್ಟನಲ್ಲಿ ವಿದ್ಯುದ್ರಾಶಯ ವಿಭವವು ಈ ಕ್ರಮದಲ್ಲಿದೆ.
 (A) $P > S > R > Q$
 (B) $S > R > Q > P$
 (C) $Q > R > S > P$
 (D) $P > Q > R > S$
10. 3p ಕಕ್ಷಕದಲ್ಲಿ ಆಂಗ್ಸಲರ್ ಮತ್ತು ರೇಡಿಯಲ್ ನೋಡ್‌ಗಳ ಸಂಖ್ಯೆ ಕ್ರಮವಾಗಿ ಹೀಗೆ ಆಗಿದೆ
 (A) 3, 1
 (B) 1, 1
 (C) 2, 1
 (D) 2, 3
11. 298K ನಲ್ಲಿ 0.01 m KCl ದ್ರಾವಣದ ರೋಧತೆಯು 1500 Ω ಆಗಿದೆ. 298 K ನಲ್ಲಿ 0.01 m KCl ದ್ರಾವಣದ ವಾಹಕತೆಯು $0.146 \times 10^{-3} \text{ S cm}^{-1}$ ಆದಲ್ಲಿ ಕೋಶದ ಕೋಶ ಸ್ಥಿರಾಂಕವು cm^{-1} ನಲ್ಲಿ ಇದಾಗಿದೆ.
 (A) 0.219
 (B) 0.291
 (C) 0.301
 (D) 0.194

SPACE FOR ROUGH WORK

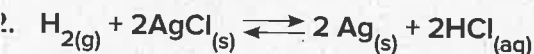

E°_{cell} at 25°C for the cell is 0.22 V. The equilibrium constant at 25°C is

- (A) 2.8×10^7 (B) 5.2×10^8
 (C) 2.8×10^5 (D) 5.2×10^4

3. For a reaction $\text{A} + 2\text{B} \rightarrow \text{Products}$, when concentration of B alone is increased half life remains the same. If concentration of A alone is doubled, rate remains the same. The unit of rate constant for the reaction is

- (A) S^{-1} (B) $\text{L mol}^{-1} \text{S}^{-1}$
 (C) $\text{mol L}^{-1} \text{S}^{-1}$ (D) atm^{-1}

4. The third ionisation enthalpy is highest in

- (A) Alkali metals (B) Alkaline earth metals
 (C) Chalcogens (D) Pnictogens

5. If the rate constant for a first order reaction is k, the time (t) required for the completion of 99% of the reaction is given by

- (A) $t = \frac{4.606}{k}$ (B) $t = \frac{2.303}{k}$ (C) $t = \frac{0.693}{k}$ (D) $t = \frac{6.909}{k}$

The rate of a gaseous reaction is given by the expression $k[\text{A}][\text{B}]^2$. If the volume of vessel is reduced to one half of the initial volume, the reaction rate as compared to original rate is

- (A) $\frac{1}{16}$ (B) $\frac{1}{8}$ (C) 8 (D) 16

The correct IUPAC name of

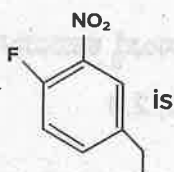

is

- (A) 4-Ethyl-1-Fluoro-2-nitrobenzene
 (B) 1-Ethyl-4-Fluoro-3-nitrobenzene
 (C) 3-Ethyl-6-Fluoronitrobenzene
 (D) 5-Ethyl-2-Fluoronitrobenzene

SPACE FOR ROUGH WORK

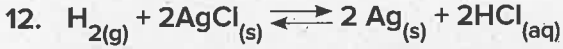

25°Cನಲ್ಲಿ ಕೋಶದ E°_{cell} ಬೆಲೆಯು 0.22 V. ಆದ್ದರಿಂದ, 25°Cನಲ್ಲಿ ಸಮಸ್ಥಿತಿ ಸ್ಥಿರಾಂಕವು ಇದಾಗಿದೆ.

(A) 2.8×10^7

(B) 5.2×10^8

(C) 2.8×10^5

(D) 5.2×10^4

13. $A + 2B \rightarrow$ ಉತ್ಪನ್ನಗಳು. ಈ ಕ್ರಿಯೆಯಲ್ಲಿ B ನ ಸಾರತೆಯನ್ನು ಮಾತ್ರ ಹೆಚ್ಚಿಸಿದಾಗ ಕ್ರಿಯೆಯ ಅರ್ಧಾಯು ಸ್ಥಿರವಾಗಿ ಉಳಿಯುತ್ತದೆ. A ನ ಸಾರತೆಯನ್ನು ಮಾತ್ರ ದ್ವಿಗುಣಗೊಳಿಸಿದಾಗ, ವೇಗವು ಬದಲಾಗುವುದಿಲ್ಲ. ಕ್ರಿಯೆಯ ಕ್ರಿಯಾವೇಗ ಸ್ಥಿರಾಂಕದ ಮೂಲಮಾನವು ಇದಾಗಿದೆ.

(A) S^{-1}

(B) $L mol^{-1} S^{-1}$

(C) $mol L^{-1} S^{-1}$

(D) atm^{-1}

14. ಮೂರನೆಯ ಅಯಾನೀಕರಣ ಎಂಥಾಲ್ಪಿಯು ಅತ್ಯಂತ ಹೆಚ್ಚಾಗಿರುವುದು

(A) ಕ್ಷಾರ ಲೋಹಗಳಲ್ಲಿ

(B) ಕ್ಷಾರ

(C) ಚಾಲ್ಕೋಜೆನ್‌ಗಳಲ್ಲಿ

(D) ನಿಕೋಜೆನ್‌ಗಳಲ್ಲಿ

15. ಪ್ರಥಮ ಕ್ರಿಯಾವರ್ಗವುಳ್ಳ ಕ್ರಿಯೆಯೊಂದಕ್ಕೆ ಕ್ರಿಯಾವೇಗ ಸ್ಥಿರಾಂಕವು k ಆದ್ದರಿಂದ, ಕ್ರಿಯೆಯು ಶೇ. 99 ರಷ್ಟು ಪೂರ್ಣಗೊಳ್ಳಲು ಬೇಕಾದ ಕಾಲ (t) ನ್ನು ಇದು ಆಗಿದೆ.

(A) $t = \frac{4.606}{k}$

(B) $t = \frac{2.303}{k}$

(C) $t = \frac{0.693}{k}$

(D) $t = \frac{6.909}{k}$

16. ಅನಿಲ ಹಂತದ ಕ್ರಿಯೆಯೊಂದರ ವೇಗವು $k[A][B]^2$ ನಿಂದ ಅಭಿವ್ಯಕ್ತವಾಗಿದೆ. ಪಾತ್ರೆಯ ಗಾತ್ರವನ್ನು ಆರಂಭಿಕ ಗಾತ್ರದ ಅರ್ಧಕ್ಕೆ ಇಳಿಸಿದಾಗ, ಆರಂಭಿಕ ವೇಗಕ್ಕೆ ಹೋಲಿಸಿದಾಗ, ಕ್ರಿಯೆಯ ವೇಗವು ಇದಾಗಿದೆ.

(A) $\frac{1}{16}$

(B) $\frac{1}{8}$

(C) 8

(D) 16



(A) 4-Ethyl-1-Fluoro-2-nitrobenzene

(B) 1-Ethyl-4-Fluoro-3-nitrobenzene

(C) 3-Ethyl-6-Fluoronitrobenzene

(D) 5-Ethyl-2-Fluoronitrobenzene

SPACE FOR ROUGH WORK

- Higher order (> 3) reactions are rare due to
- (A) Shifting of equilibrium towards reactants due to elastic collisions
 - (B) Loss of active species on collision
 - (C) Low probability of simultaneous collision of all reacting species
 - (D) Increase in entropy as more molecules are involved
- Arrange benzene, n-hexane and ethyne in decreasing order of their acidic behaviour
- (A) Benzene $>$ n-hexane $>$ ethyne
 - (B) n-hexane $>$ Benzene $>$ ethyne
 - (C) ethyne $>$ n-hexane $>$ Benzene
 - (D) ethyne $>$ Benzene $>$ n-hexane
- A colloidal solution is subjected to an electric field than colloidal particles move towards anode. The amount of electrolytes of BaCl_2 , AlCl_3 and NaCl required to coagulate the given colloid is in the order
- (A) $\text{NaCl} > \text{BaCl}_2 > \text{AlCl}_3$
 - (B) $\text{BaCl}_2 > \text{AlCl}_3 > \text{NaCl}$
 - (C) $\text{AlCl}_3 = \text{NaCl} = \text{BaCl}_2$
 - (D) $\text{AlCl}_3 > \text{BaCl}_2 > \text{NaCl}$
- Which of the following is an incorrect statement?
- (A) Hydrogen bonding is stronger than dispersion forces
 - (B) Sigma bonds are stronger than π -bonds
 - (C) Ionic bonding is non-directional
 - (D) σ -electrons are referred to as mobile electrons
- Zeta potential is
- (A) Potential required to bring about coagulation of a colloidal sol.
 - (B) Potential required to give the particle a speed of 1 cm S^{-1}
 - (C) Potential difference between fixed charged layer and the diffused layer having opposite charges
 - (D) Potential energy of the colloidal particles.

SPACE FOR ROUGH WORK

18. ಉನ್ನತ ಕ್ರಿಯಾವರ್ಗ (>3) ವುಳ್ಳ ಕ್ರಿಯೆಗಳು ಅತಿ ವಿರಳವಾಗಲು ಕಾರಣವು ಇದಾಗಿದೆ.
- (A) ಘರ್ಷಣೆಗಳು ಸ್ಥಿತಿ ಸ್ಥಾಪಕವಾದ್ದರಿಂದ ಸಮಸ್ಥಿತಿಯು ಕಾರಕಗಳ ಕಡೆಗೆ ವರ್ಗಾವಣೆಯಾಗುತ್ತದೆ.
- (B) ಘರ್ಷಣೆಯಲ್ಲಿ ಸಕ್ರಿಯ ಪ್ರಬೇಧಗಳು ನಶಿಸುತ್ತವೆ
- (C) ಎಲ್ಲ ಕಾರಕ ಪ್ರಬೇಧಗಳು ಏಕಕಾಲದಲ್ಲೇ ಘರ್ಷಣೆಯಾಗುವ ಸಂಭಾವ್ಯತೆಯು ಕಡಿಮೆಯಾಗಿದೆ.
- (D) ಹೆಚ್ಚು ಅಣುಗಳು ಭಾಗವಹಿಸುವುದರಿಂದ ಎಂಟ್ರೋಪಿಯ ಹೆಚ್ಚುವಿಕೆ
19. ಅವುಗಳ ಆಮ್ಲೀಯ ವರ್ತನೆಯ ಇಳಿಕೆ ಕ್ರಮದಲ್ಲಿ ಬೆಂಜೀನ್, n-ಹೆಕ್ಸೇನ್ ಮತ್ತು ಈಥೈನ್ ಅನ್ನು ಜೋಡಿಸಿ
- (A) ಬೆಂಜೀನ್ > n-ಹೆಕ್ಸೇನ್ > ಈಥೈನ್
- (B) n-ಹೆಕ್ಸೇನ್ > ಬೆಂಜೀನ್ > ಈಥೈನ್
- (C) ಈಥೈನ್ > n-ಹೆಕ್ಸೇನ್ > ಬೆಂಜೀನ್
- (D) ಈಥೈನ್ > ಬೆಂಜೀನ್ > n-ಹೆಕ್ಸೇನ್
20. ಒಂದು ಕಲಿಲ ದ್ರಾವಣವನ್ನು ವಿದ್ಯುತ್ ಕ್ಷೇತ್ರಕ್ಕೆ ಒಳಪಡಿಸಿದಾಗ ಕಲಿಲ ಕಣಗಳು ಧನಾಗ್ರ (ಆನೋಡ್) ಕಡೆಗೆ ಚಲಿಸುತ್ತದೆ. ಕಲಿಲವು ಗರಣೆಗಟ್ಟಲು $BaCl_2$, $AlCl_3$ ಮತ್ತು $NaCl$ ವಿದ್ಯುದ್ವಿಭಾಜ್ಯಗಳ ಪರಿಮಾಣವು ಈ ಕ್ರಮದಲ್ಲಿದೆ.
- (A) $NaCl > BaCl_2 > AlCl_3$
- (B) $BaCl_2 > AlCl_3 > NaCl$
- (C) $AlCl_3 = NaCl = BaCl_2$
- (D) $AlCl_3 > BaCl_2 > NaCl$
21. ಈ ಕೆಳಗಿನವುಗಳಲ್ಲಿ ಯಾವುದು ಸರಿಯಾದ ಹೇಳಿಕೆಯಾಗಿಲ್ಲ?
- (A) ಹೈಡ್ರೋಜನ್ ಬಂಧವು ಪರೀಕ್ಷೇಪಣ ಬಲಕ್ಕಿಂತ ಪ್ರಬಲವಾಗಿದೆ
- (B) ಸಿಗ್ಮಾ ಬಂಧವು ಪೈ ಬಂಧಕ್ಕಿಂತ ಪ್ರಬಲವಾಗಿದೆ.
- (C) ಅಯಾನಿಕ್ ಬಂಧವು ನಿರ್ದಿಷ್ಟ ದಿಕ್ಕು ಇಲ್ಲದಾಗಿದೆ.
- (D) σ -ಎಲೆಕ್ಟ್ರಾನ್ ಗಳನ್ನು ಸಂಚಾರಿ ಎಲೆಕ್ಟ್ರಾನ್ ಗಳೆಂದು ಉಲ್ಲೇಖಿಸಲಾಗಿದೆ
22. ಜೀಟಾ ವಿಭವ ಎಂದರೆ
- (A) ಒಂದು ಕಲಿಲಸಾಲ್ ಗರಣೆಗಟ್ಟುಪಿಕ್ಗೆ ಬೇಕಾಗುವ ವಿಭವ
- (B) ಕಣಗಳಿಗೆ 1 cm S^{-1} ವೇಗವನ್ನು ಕೊಡಲು ಬೇಕಾದ ವಿಭವ
- (C) ವಿರುದ್ಧ ಆವೇಶಗಳ ಮೇಲಿನ ಬಿಗಿಯಾದ ಪದರ ಮತ್ತು ಚದುರಿದ ಪದರದ ನಡುವಿನ ವಿಭವ ವ್ಯತ್ಯಾಸ
- (D) ಕಲಿಲ ಕಣದ ಸಂಭಾವ್ಯ ಶಕ್ತಿ

SPACE FOR ROUGH WORK

23. Which of the following compound on heating gives N_2O ?
- (A) $Pb(NO_3)_2$ (B) NH_4NO_3
 (C) NH_4NO_2 (D) $NaNO_3$
24. Which of the following property is true for the given sequence $NH_3 > PH_3 > AsH_3 > SbH_3 > BiH_3$?
- (A) Reducing property (B) Thermal stability
 (C) Bond angle (D) Acidic character
25. The correct order of boiling point in the following compounds is
- (A) $HF > H_2O > NH_3$ (B) $H_2O > HF > NH_3$
 (C) $NH_3 > H_2O > HF$ (D) $NH_3 > HF > H_2O$
26. XeF_6 on partial hydrolysis gives a compound X, which has square pyramidal geometry 'X' is
- (A) XeO_3 (B) XeO_4
 (C) $XeOF_4$ (D) XeO_2F_2
27. A colourless, neutral, paramagnetic oxide of Nitrogen 'P' on oxidation gives reddish brown gas Q. Q on cooling gives colourless gas R. R on reaction with P gives blue solid S. Identify P, Q, R, S, respectively
- (A) N_2O NO NO_2 N_2O_5 (B) N_2O NO_2 N_2O_4 N_2O_3
 (C) NO NO_2 N_2O_4 N_2O_3 (D) NO NO N_2O_4 N_2O_5
28. Which of the following does not represent property stated against it?
- (A) $CO^{+2} < Fe^{+2} < Mn^{+2}$ – Ionic size
 (B) $Ti < V < Mn$ – Number of oxidation states
 (C) $Cr^{+2} < Mn^{+2} < Fe^{+2}$ – Paramagnetic behaviour
 (D) $Sc > Cr > Fe$ – Density

SPACE FOR ROUGH WORK

23. ಈ ಕೆಳಗಿನ ಯಾವ ಸಂಯುಕ್ತವನ್ನು ಕಾಯಿಸಿದಾಗ N_2O ನ್ನು ಕೊಡುತ್ತದೆ ?
 (A) $Pb(NO_3)_2$ (B) NH_4NO_3
 (C) NH_4NO_2 (D) $NaNO_3$
24. $NH_3 > PH_3 > AsH_3 > SbH_3 > BiH_3$ ಈ ಅನುಕ್ರಮಕ್ಕೆ ಯಾವ ಕೆಳಗಿನ ಗುಣವು ಸರಿಯಾಗಿದೆ?
 (A) ಅಪಕರ್ಷಣ ಗುಣ (B) ಉಷ್ಣತಾ ಸ್ಥಿರತೆ
 (C) ಬಂಧ ಕೋನ (D) ಆಮ್ಲೀಯ ಗುಣ
25. ಈ ಕೆಳಗಿನ ಸಂಯುಕ್ತಗಳಲ್ಲಿ ಕುದಿಯುವ ಬಿಂದುವಿನ ಸರಿಯಾದ ಕ್ರಮವನ್ನು ಹೊಂದಿರುವುದು.
 (A) $HF > H_2O > NH_3$ (B) $H_2O > HF > NH_3$
 (C) $NH_3 > H_2O > HF$ (D) $NH_3 > HF > H_2O$
26. XeF_6 ನ್ನು ಆಂಶಿಕ ಜಲವಿಭಜನೆಗೊಳಿಸಿದಾಗ 'X' ಸಂಯುಕ್ತವನ್ನು ಕೊಡುತ್ತದೆ, ಇದಕ್ಕೆ ವರ್ಗ ಪರಿಮಿಡೀಯ ಜ್ಯಾಮಿತಿಯಿದೆ. 'X' ಇದಾಗಿದೆ.
 (A) XeO_3 (B) XeO_4
 (C) $XeOF_4$ (D) XeO_2F_2
27. ನೈಟ್ರೋಜನ್‌ನ ವರ್ಣರಹಿತ, ತಟಸ್ಥವಾದ, ಕಾಂತೀಯತೆ ಇರುವ ಆಕ್ಸೈಡ್ 'P' ಯು ಉತ್ಕರ್ಷಣೆಗೊಂಡಾಗ ಕೆಂಪು ಮಿಶ್ರಿತ ಕಂದು ಬಣ್ಣದ ಅನಿಲ 'Q' ನ್ನು ಕೊಡುತ್ತದೆ. Q ನ್ನು ತಣಿಸಿದಾಗ ವರ್ಣರಹಿತ ಅನಿಲ "R" ನ್ನು ಉಂಟು ಮಾಡುತ್ತದೆ. P ಜೊತೆ R ವರ್ತಿಸಿದಾಗ ನೀಲಿ ಬಣ್ಣದ ಘನ ವಸ್ತು S ನ್ನು ನೀಡುತ್ತದೆ. ಕ್ರಮವಾಗಿ P, Q, R, S ನ್ನು ಪತ್ತೆ ಹಚ್ಚಿರಿ
 (A) N_2O NO NO_2 N_2O_5 (B) N_2O NO_2 N_2O_4 N_2O_3
 (C) NO NO_2 N_2O_4 N_2O_3 (D) NO NO N_2O_4 N_2O_5
28. ಈ ಕೆಳಗಿನವುಗಳಲ್ಲಿ ಯಾವುದು ಅದರ ಮುಂದೆ ಹೇಳಿದ ಗುಣವನ್ನು ಪ್ರತಿನಿಧಿಸುವುದಿಲ್ಲ?
 (A) $CO^{+2} < Fe^{+2} < Mn^{+2}$ - ಆಯಾನಿಕ್ ಗಾತ್ರ
 (B) $Ti < V < Mn$ - ಉತ್ಕರ್ಷಣಾ ಸ್ಥಿತಿ ಸಂಖ್ಯೆ
 (C) $Cr^{+2} < Mn^{+2} < Fe^{+2}$ - ಪ್ಯಾರಾಕಾಂತೀಯ ವರ್ತನೆ
 (D) $Sc > Cr > Fe$ - ಸಾಂದ್ರತೆ

SPACE FOR ROUGH WORK

- Which one of the following is correct for all elements from Sc to Cu?
- (A) The lowest oxidation state shown by them is +2
 - (B) 4s orbital is completely filled in the ground state
 - (C) 3d orbital is not completely filled in the ground state
 - (D) The ions in +2 oxidation states are paramagnetic
- When the absolute temperature of ideal gas is doubled and pressure is halved, the volume of gas
- (A) will be half of original volume
 - (B) will be 4 times the original volume
 - (C) will be 2 times the original volume
 - (D) will be 1/4th times the original volume

Which of the following pairs has both the ions coloured in aqueous solution? [Atomic numbers of Sc = 21, Ti = 22, Ni = 28, Cu = 29, Mn = 25]

- (A) Sc^{3+} , Mn^{2+} (B) Ni^{2+} , Ti^{4+} (C) Ti^{3+} , Cu^+ (D) Mn^{2+} , Ti^{3+}

- For the crystal field splitting in octahedral complexes,
- (A) the energy of the e_g orbitals will decrease by $(3/5)\Delta_0$ and that of the t_{2g} will increase by $(2/5)\Delta_0$
 - (B) the energy of the e_g orbitals will increase by $(3/5)\Delta_0$ and that of the t_{2g} will decrease by $(2/5)\Delta_0$
 - (C) the energy of the e_g orbitals will increase by $(3/5)\Delta_0$ and that of the t_{2g} will increase by $(2/5)\Delta_0$
 - (D) the energy of the e_g orbitals will decrease by $(3/5)\Delta_0$ and that of the t_{2g} will decrease by $(2/5)\Delta_0$

Peroxide effect is observed with the addition of HBr but not with the addition of HI to unsymmetrical alkene because

- (A) H-I bond is stronger than H-Br and is not cleaved by the free radical
- (B) H-I bond is weaker than H-Br bond so that iodine free radicals combine to form iodine molecules
- (C) Bond strength of HI and HBr are same but free radicals are formed in HBr
- (D) All of these

SPACE FOR ROUGH WORK

29. Sc ನಿಂದ Cu ವಿನ ಎಲ್ಲಾ ಧಾತುಗಳಿಗೆ ಈ ಕೆಳಗಿನ ಯಾವುದು ಸರಿಯಾಗಿದೆ ?

- (A) +2 ಇವುಗಳ ಅತ್ಯಂತ ಕಡಿಮೆ ಉತ್ಕರ್ಷಣಾ ಸಂಖ್ಯೆಯಾಗಿದೆ
(B) ತಳಸ್ಥಿತಿಯಲ್ಲಿ 4s ಕಕ್ಷಕವು ಪೂರ್ಣವಾಗಿ ತುಂಬಿರುತ್ತದೆ
(C) ತಳಸ್ಥಿತಿಯಲ್ಲಿ 3d ಕಕ್ಷಕವು ಪೂರ್ಣವಾಗಿ ತುಂಬಿರುವುದಿಲ್ಲ
(D) +2 ಉತ್ಕರ್ಷಣಾ ಸ್ಥಿತಿಯುಳ್ಳ ಅಯಾನುಗಳಿಗೆ ಕಾಂತೀಯವಾಗಿವೆ

30. ಆದರ್ಶ ಅನಿಲದ ನಿರಪೇಕ್ಷ ಉಷ್ಣತೆಯನ್ನು ದ್ವಿಗುಣಗೊಳಿಸಿ ಮತ್ತು ಒತ್ತಡವನ್ನು ಅರ್ಧಗೊಳಿಸಿದಾಗ, ಅನಿಲದ ಗಾತ್ರವು

- (A) ಮೂಲಗಾತ್ರದ ಅರ್ಧದಷ್ಟಾಗುತ್ತದೆ (B) ಮೂಲಗಾತ್ರದ ನಾಲ್ಕರಷ್ಟಾಗುತ್ತದೆ
(C) ಮೂಲಗಾತ್ರದ ಎರಡರಷ್ಟಾಗುತ್ತದೆ (D) ಮೂಲಗಾತ್ರದ 1/4 ರಷ್ಟಾಗುತ್ತದೆ

31. ಈ ಕೆಳಗಿನವುಗಳಲ್ಲಿ ಯಾವ ಜೊತೆ ಅಯಾನುಗಳು ಜಲೀಯ ದ್ರಾವಣದಲ್ಲಿ ಬಣ್ಣವನ್ನು ಹೊಂದಿದೆ?

- [ಪರಮಾಣು ಸಂಖ್ಯೆ : Sc = 21, Ti = 22, Ni = 28, Cu = 29, Mn = 25]
(A) Sc^{3+} , Mn^{2+} (B) Ni^{2+} , Mn^{2+}
(C) Ti^{3+} , Cu^{+} (D) Mn^{2+} , Ti^{3+}

32. ಅಷ್ಟಮುಖಿ ಸಮನ್ವಯಿ ಸಂಯುಕ್ತಗಳಲ್ಲಿ ಸ್ಪಟಿಕ ಕ್ಷೇತ್ರ, ವಿಭಜನೆಯು

- (A) e_g ಕಕ್ಷಕಗಳ ಶಕ್ತಿ $(3/5)\Delta_0$ ನಷ್ಟು ಕಡಿಮೆಯಾಗುತ್ತದೆ ಮತ್ತು t_{2g} ಕಕ್ಷಕಗಳ ಶಕ್ತಿ $(2/5)\Delta_0$ ನಷ್ಟು ಹೆಚ್ಚಾಗುತ್ತದೆ.
(B) e_g ಕಕ್ಷಕಗಳ ಶಕ್ತಿ $(3/5)\Delta_0$ ನಷ್ಟು ಹೆಚ್ಚಾಗುತ್ತದೆ ಮತ್ತು t_{2g} ಕಕ್ಷಕಗಳ ಶಕ್ತಿ $(2/5)\Delta_0$ ನಷ್ಟು ಕಡಿಮೆಯಾಗುತ್ತದೆ.
(C) e_g ಕಕ್ಷಕಗಳ ಶಕ್ತಿ $(3/5)\Delta_0$ ನಷ್ಟು ಹೆಚ್ಚಾಗುತ್ತದೆ ಮತ್ತು t_{2g} ಕಕ್ಷಕಗಳ ಶಕ್ತಿ $(2/5)\Delta_0$ ನಷ್ಟು ಹೆಚ್ಚಾಗುತ್ತದೆ.
(D) e_g ಕಕ್ಷಕಗಳ ಶಕ್ತಿ $(3/5)\Delta_0$ ನಷ್ಟು ಕಡಿಮೆಯಾಗುತ್ತದೆ ಮತ್ತು t_{2g} ಕಕ್ಷಕಗಳ ಶಕ್ತಿ $(2/5)\Delta_0$ ನಷ್ಟು ಕಡಿಮೆಯಾಗುತ್ತದೆ

33. ಅಸಮ್ಮತಿಯ ಆಲ್ಕೀನ್‌ಗಳು H-Br ಜೊತೆ ಸಂಕಲನಗೊಂಡಾಗ ಪೆರಾಕ್ಸೈಡ್ ಪರಿಣಾಮವನ್ನು ಗಮನಿಸಬಹುದು. ಆದರೆ ಈ ಪರಿಣಾಮವನ್ನು HI ಜೊತೆ ಗಮನಿಸಲಾಗುವುದಿಲ್ಲ, ಏಕೆಂದರೆ

- (A) H-I ಬಂಧವು H-Br ಬಂಧಕ್ಕಿಂತ ಪ್ರಬಲವಾಗಿದೆ ಮತ್ತು ಮುಕ್ತ ಮಾತ್ರಕೆಗಳಿಂದ ಛೇದಿಸಲಾಗುವುದಿಲ್ಲ
(B) H-I ಬಂಧವು H-Br ಬಂಧಕ್ಕಿಂತ ದುರ್ಬಲವಾಗಿದೆ. ಇದರಿಂದ ಅಯೋಡಿನ್ ಮುಕ್ತ ಮಾತ್ರಕೆಗಳು ಸಂಯೋಗಗೊಂಡು ಅಯೋಡಿನ್ ಅಣುಗಳಾಗುತ್ತವೆ
(C) H-I ಮತ್ತು H-Br ಬಂಧ ಸಾಮರ್ಥ್ಯವು ಒಂದೇ ಸಮವಾಗಿವೆ. ಆದರೆ H-Br ನಲ್ಲಿ ಮುಕ್ತ ಮಾತ್ರಕೆಗಳು ಉಂಟಾಗುತ್ತದೆ.
(D) ಈ ಎಲ್ಲವೂ ಆಗಿದೆ.



SPACE FOR ROUGH WORK

34. The IUPAC name of $[\text{Co}(\text{NH}_3)_5(\text{CO}_3)] \text{Cl}$ is
- (A) Pentaamminecarbonatocobalt (III) Chloride
 (B) Carbonatopentamminecobalt (III) Chloride
 (C) Pentaamminecarbonatocobaltate (III) Chloride
 (D) Pentaammine cobalt (III) Carbonate Chloride

35. Homoleptic complexes among the following are
- (A) $\text{K}_3[\text{Al}(\text{C}_2\text{O}_4)_3]$, (B) $[\text{CoCl}_2(\text{en})_2]^+$ (C) $\text{K}_2[\text{Zn}(\text{OH})_4]$
- (A) A only (B) (A) and (B) only
 (C) (A) and (C) only (D) (C) only

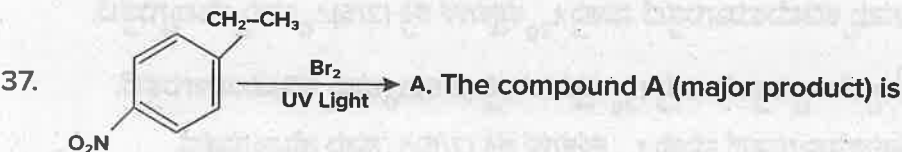
36. The correct order for wavelengths of light absorbed in the complex ions $[\text{CoCl}(\text{NH}_3)_5]^{2+}$, $[\text{Co}(\text{NH}_3)_6]^{3+}$ and $[\text{Co}(\text{CN})_6]^{3-}$ is
- (A) $[\text{CoCl}(\text{NH}_3)_5]^{2+} > [\text{Co}(\text{NH}_3)_6]^{3+} > [\text{Co}(\text{CN})_6]^{3-}$
 (B) $[\text{Co}(\text{NH}_3)_6]^{3+} > [\text{Co}(\text{CN})_6]^{3-} > [\text{CoCl}(\text{NH}_3)_5]^{2+}$
 (C) $[\text{Co}(\text{CN})_6]^{3-} > [\text{CoCl}(\text{NH}_3)_5]^{2+} > [\text{Co}(\text{CN})_6]^{3-}$
 (D) $[\text{Co}(\text{NH}_3)_6]^{3+} > [\text{CoCl}(\text{NH}_3)_5] > [\text{Co}(\text{CN})_6]^{3-}$

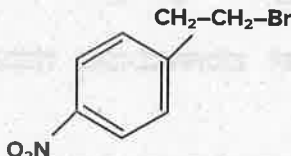

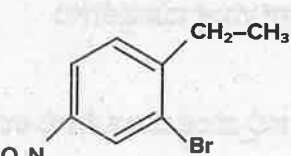
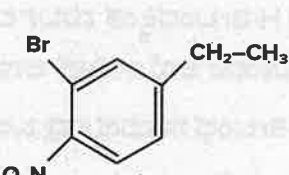
- (A)  (B) 
- (C)  (D) 

SPACE FOR ROUGH WORK

34. $[\text{Co}(\text{NH}_3)_5(\text{CO}_3)] \text{Cl}$ ನ IUPAC ಹೆಸರು

- (A) ಪೆಂಟಾ ಅಮೀನ್ ಕಾರ್ಬೋನೇಟೋ ಕೋಬಾಲ್ಟ್(III) ಕ್ಲೋರೈಡ್
 (B) ಕಾರ್ಬೋನೇಟೋ ಪೆಂಟಾ ಅಮೀನ್ ಕೋಬಾಲ್ಟ್(III) ಕ್ಲೋರೈಡ್
 (C) ಪೆಂಟಾ ಅಮೀನ್ ಕಾರ್ಬೋನೇಟೋ ಕೋಬಾಲ್ಟ್(III) ಕ್ಲೋರೈಡ್
 (D) ಪೆಂಟಾ ಅಮೀನ್ ಕೋಬಾಲ್ಟ್(III) ಕಾರ್ಬೋನೇಟೋ ಕ್ಲೋರೈಡ್

35. ಈ ಕೆಳಗಿನವುಗಳಲ್ಲಿ ಹೊಮೋಲೆಪ್ಟಿಕ್ ಸಂಕೀರ್ಣವು/ಗಳು

- (A) $\text{K}_3 [\text{Al}(\text{C}_2\text{O}_4)_3]$, (B) $[\text{CoCl}_2(\text{en})_2]^+$ (C) $\text{K}_2 [\text{Zn}(\text{OH})_4]$

(A) A ಮಾತ್ರ

(B) (A) ಮತ್ತು (B) ಮಾತ್ರ

(C) (A) ಮತ್ತು (C) ಮಾತ್ರ

(D) (C) ಮಾತ್ರ

36. ಬೆಳಕಿನ ತರಂಗಾಂತರವನ್ನು ಹೀರಿಕೊಳ್ಳುವ ಸಂಕೀರ್ಣ ಆಯಾನುಗಳ ಸರಿಯಾದ ಕ್ರಮವು

$[\text{CoCl}(\text{NH}_3)_5]^{2+}$, $[\text{Co}(\text{NH}_3)_6]^{3+}$ ಮತ್ತು $[\text{Co}(\text{CN})_6]^{3-}$

(A) $[\text{CoCl}(\text{NH}_3)_5]^{2+} > [\text{Co}(\text{NH}_3)_6]^{3+} > [\text{Co}(\text{CN})_6]^{3-}$

(B) $[\text{Co}(\text{NH}_3)_6]^{3+} > [\text{Co}(\text{CN})_6]^{3-} > [\text{CoCl}(\text{NH}_3)_5]^{2+}$

(C) $[\text{Co}(\text{CN})_6]^{3-} > [\text{CoCl}(\text{NH}_3)_5]^{2+} > [\text{Co}(\text{CN})_6]^{3-}$

(D) $[\text{Co}(\text{NH}_3)_6]^{3+} > [\text{CoCl}(\text{NH}_3)_5] > [\text{Co}(\text{CN})_6]^{3-}$

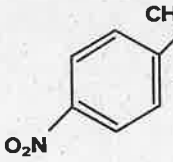
37.  A. A ಸಂಯುಕ್ತವು (ಅಧಿಕ ಪ್ರಮಾಣದ ಉತ್ಪನ್ನ)

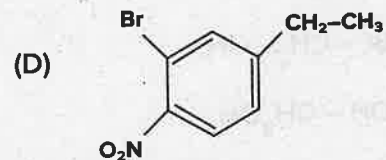
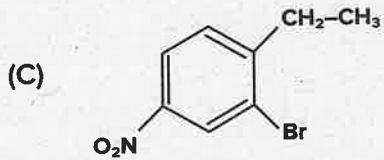
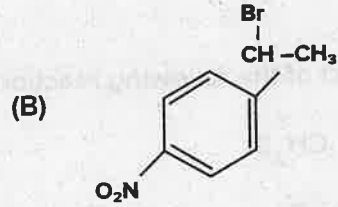
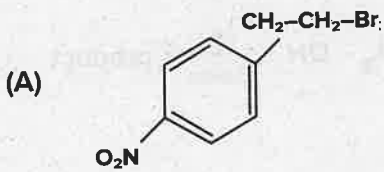

SPACE FOR ROUGH WORK

8. Bond enthalpies of A_2 , B_2 and AB are in the ratio 2 : 1 : 2. If bond enthalpy of formation of AB is -100 KJ mol^{-1} . The bond enthalpy of B_2 is
- (A) 100 KJ mol^{-1} (B) 50 KJ mol^{-1}
 (C) 200 KJ mol^{-1} (D) 150 KJ mol^{-1}
9. The order of reactivity of the compounds $C_6H_5CH_2Br$, $C_6H_5CH(C_6H_5)Br$, $C_6H_5CH(CH_3)Br$ and $C_6H_5C(CH_3)(C_6H_5)Br$ in S_N^2 reaction is

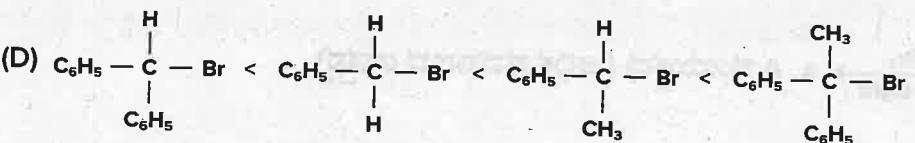
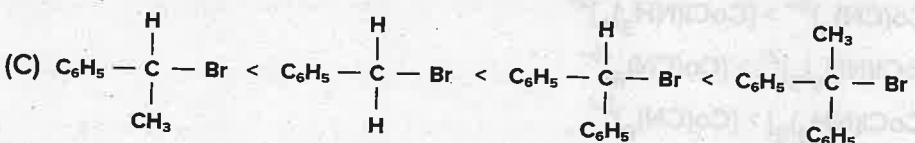
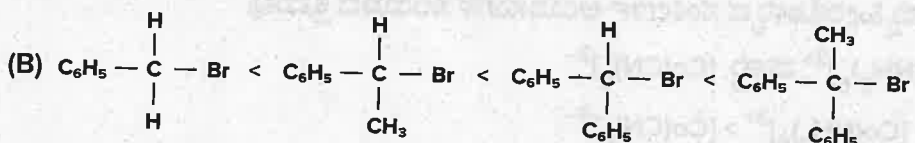
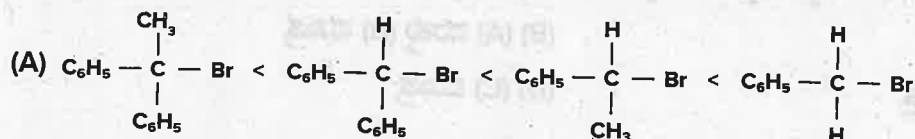

The major product of the following reaction is $CH_2 = CH - CH_2 - OH \xrightarrow[\text{Excess}]{HBr}$ product

- (A) $CH_3 - CHBr - CH_2Br$
 (B) $CH_2 = CH - CH_2Br$
 (C) $CH_3 - CHBr - CH_2 - OH$
 (D) $CH_3 - CHOH - CH_2OH$

SPACE FOR ROUGH WORK

38. A_2 , B_2 ಮತ್ತು AB ಗಳ ಬಂಧ ಎಂಥಾಲ್ಪಿಯು 2:1:2 ರ ಅನುಪಾತದಲ್ಲಿದೆ. AB ರೂಪಣೆಯ ಬಂಧ ಎಂಥಾಲ್ಪಿಯು -100 KJ mol^{-1} ಆದಲ್ಲಿ, B_2 ವಿನ ಬಂಧ ಎಂಥಾಲ್ಪಿಯು

(A) 100 KJ mol^{-1}

(B) 50 KJ mol^{-1}

(C) 200 KJ mol^{-1}

(D) 150 KJ mol^{-1}

39. S_N^2 ಕ್ರಿಯೆಯಲ್ಲಿ $C_6H_5CH_2Br$, $C_6H_5CH(C_6H_5)Br$, $C_6H_5CH(CH_3)Br$ ಮತ್ತು $C_6H_5C(CH_3)(C_6H_5)Br$ ಸಂಯುಕ್ತಗಳ ಕ್ರಿಯಾಶೀಲತೆಯು ಈ ಅನುಕ್ರಮದಲ್ಲಿದೆ.

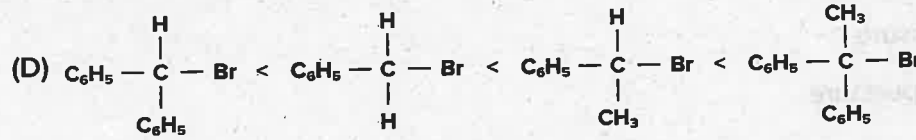
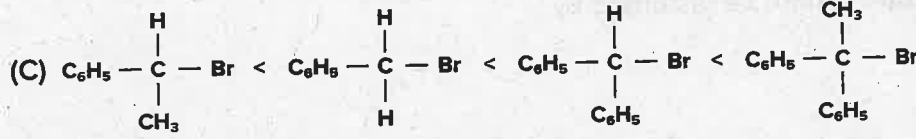
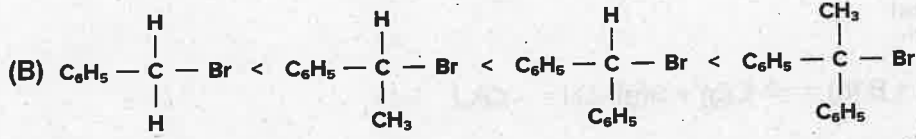
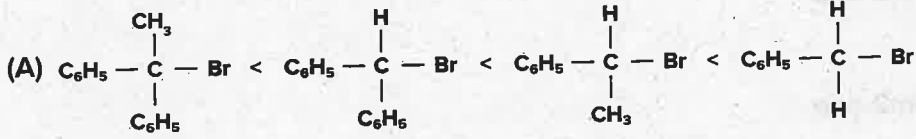

40. ಈ ಕೆಳಗಿನ ಕ್ರಿಯೆಯ ಅಧಿಕ ಪ್ರಮಾಣದ ಉತ್ಪನ್ನವು $CH_2 = CH - CH_2 - OH \xrightarrow[\text{ಅಧಿಕ}]{HBr} \text{ಉತ್ಪನ್ನ}$



SPACE FOR ROUGH WORK

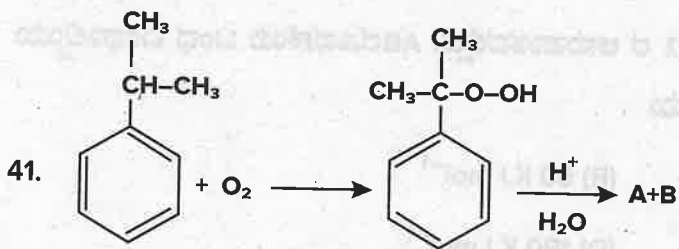

The product 'A' gives white precipitate when treated with bromine water. The product 'B' is treated with Barium hydroxide to give the product C. The compound C is heated strongly to form product D. The product D is

- (A) 4-Methylpent-3-en-2-one
- (B) But-2 enal
- (C) 3-Methylpent-3-en-2-one
- (D) 2-Methylbut-2-enal



The equilibrium constant cannot be disturbed by

- (A) Addition of A
- (B) Addition of D
- (C) Increasing of pressure
- (D) Increasing of temperature

43. An organic compound 'X' on treatment with PCC in dichloromethane gives the compound Y. Compound 'Y' reacts with I_2 and alkali to form yellow precipitate of triiodomethane. The compound X is

- (A) CH_3CHO
- (B) CH_3COCH_3
- (C) CH_3CH_2OH
- (D) CH_3COOH

SPACE FOR ROUGH WORK

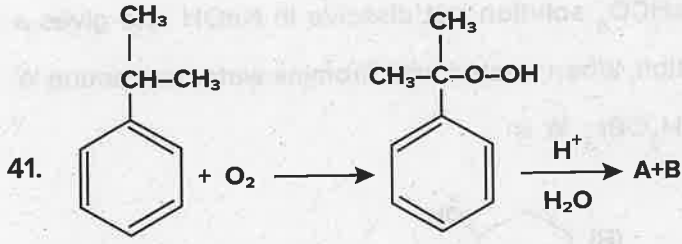

ಜಲೀಯ ಬ್ರೋಮಿನ್‌ನೊಂದಿಗೆ ವರ್ತಿಸಿದಾಗ ಉತ್ಪನ್ನ 'A' ಯು ಬಿಳಿ ಒತ್ತರವನ್ನು ಕೊಡುತ್ತದೆ. 'B' ಉತ್ಪನ್ನವನ್ನು ಬೇರಿಯಂ ಹೈಡ್ರಾಕ್ಸೈಡ್‌ನೊಂದಿಗೆ ವರ್ತಿಸಿದಾಗ C ಉತ್ಪನ್ನ ಸಿಗುತ್ತದೆ. C ಸಂಯುಕ್ತವನ್ನು ಪ್ರಬಲವಾಗಿ ಕಾಯಿಸಿದಾಗ D ಉತ್ಪನ್ನ ಉಂಟಾಗುತ್ತದೆ.

- (A) 4 ಮಿಥೈಲ್ ಪೆಂಟ್-3-ಈನ್ -2-ಒನ್
 (B) ಬ್ಯೂಟ್-2- ಈನಾಲ್
 (C) 3 ಮಿಥೈಲ್ ಪೆಂಟ್ 3-ಈನ್ -2-ಒನ್
 (D) 2ಮೀಥೈಲ್ ಬ್ಯೂಟ್-2- ಈನಾಲ್

42. $A(g) + B(g) \rightleftharpoons C(g) + D(g)$; $\Delta H = -QKJ$ ಕ್ರಿಯೆಗೆ ಸಮಸ್ಥಿತಿಯು ಈ ಕೆಳಗಿನವುಗಳಿಂದ ಕದಲುವುದಿಲ್ಲ.

- (A) A ನ ಸೇರಿಸುವಿಕೆ
 (B) D ನ ಸೇರಿಸುವಿಕೆ
 (C) ಒತ್ತಡದ ಹೆಚ್ಚುವಿಕೆ
 (D) ಉಷ್ಣತೆಯ ಹೆಚ್ಚುವಿಕೆ

43. ಸಾವಯವ ಸಂಯುಕ್ತ 'X' ನ್ನು ಡೈಕ್ರೋರೋಮೀಥೇನ್ ಇರುವ PCC ಜೊತೆ ವರ್ತಿಸಿದಾಗ Y ಸಂಯುಕ್ತವನ್ನು ಕೊಡುತ್ತದೆ. Y ಸಂಯುಕ್ತವು I_2 ಮತ್ತು ಕ್ಷಾರದೊಂದಿಗೆ ವರ್ತಿಸಿ ಟ್ರೈಐಯೋಡೋಮೀಥೇನ್ ಹಳದಿ ಒತ್ತರವನ್ನು ಕೊಡುತ್ತದೆ. ಸಂಯುಕ್ತ X ಇದಾಗಿದೆ.

- (A) CH_3CHO
 (B) CH_3COCH_3
 (C) CH_3CH_2OH
 (D) CH_3COOH

SPACE FOR ROUGH WORK

4. A compound 'A' (C_7H_8O) is insoluble in $NaHCO_3$ solution but dissolve in $NaOH$ and gives a characteristic colour with neutral $FeCl_3$ solution. When treated with Bromine water compound 'A' forms the compound B with the formula $C_7H_5OBr_3$. 'A' is

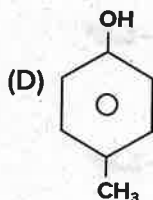
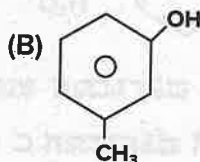
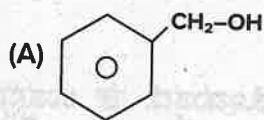

5. In set of reactions, identify D

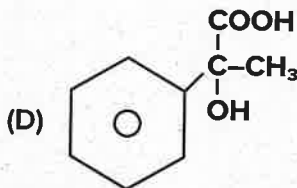
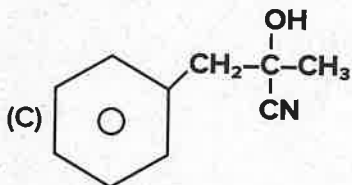
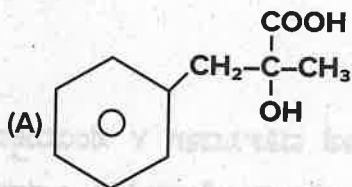
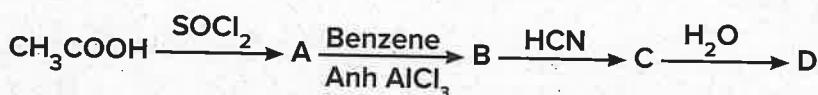

SPACE FOR ROUGH WORK

44. (C₇H₈O) ಸಂಯುಕ್ತ (A) NaHCO₃ ನಲ್ಲಿ ವಿಲೀನಗೊಳ್ಳುವುದಿಲ್ಲ. ಆದರೆ NaOH ನಲ್ಲಿ ವಿಲೀನಗೊಳ್ಳುತ್ತದೆ ಮತ್ತು ತಟಸ್ಥ FeCl₃ ದ್ರಾವಣದೊಂದಿಗೆ ನಿರ್ದಿಷ್ಟ ವರ್ಣವನ್ನು ಕೊಡುತ್ತದೆ. ಸಂಯುಕ್ತ 'A'ಯು ಜಲೀಯ ಬ್ರೋಮೀನ್ ನೊಂದಿಗೆ ವರ್ತಿಸಿದಾಗ C₇H₅OBr₃ ಅಣುಸೂತ್ರವಿರುವ ಸಂಯುಕ್ತ B ಅನ್ನು ಉಂಟುಮಾಡುತ್ತದೆ. A ಯು ಇದಾಗಿದೆ :

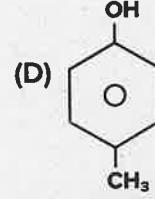
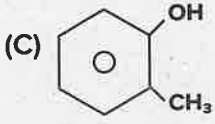
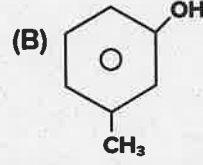
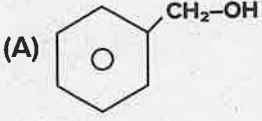

45. ಕ್ರಿಯೆಗಳ ಈ ಗುಂಪಿನಲ್ಲಿ, D ಅನ್ನು ಪತ್ತೆ ಹಚ್ಚಿರಿ.

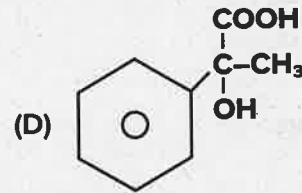
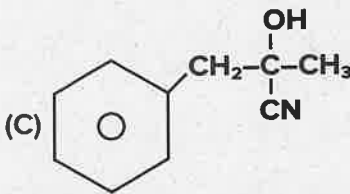
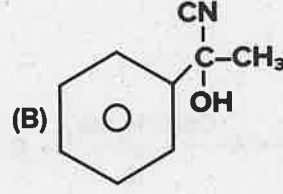
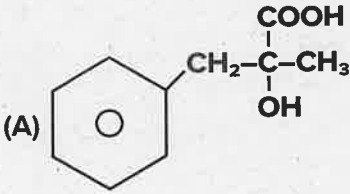
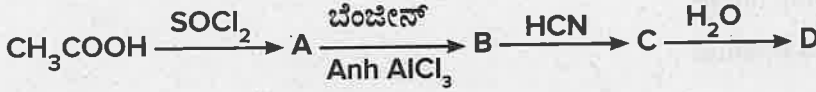

SPACE FOR ROUGH WORK

46. K_a values for acids H_2SO_3 , HNO_2 , CH_3COOH and HCN are respectively 1.3×10^{-2} , 4×10^{-4} , 1.8×10^{-5} and 4×10^{-10} , which of the above acids produces stronger conjugate base in aqueous solution?

- (A) H_2SO_3 (B) HNO_2
 (C) CH_3COOH (D) HCN

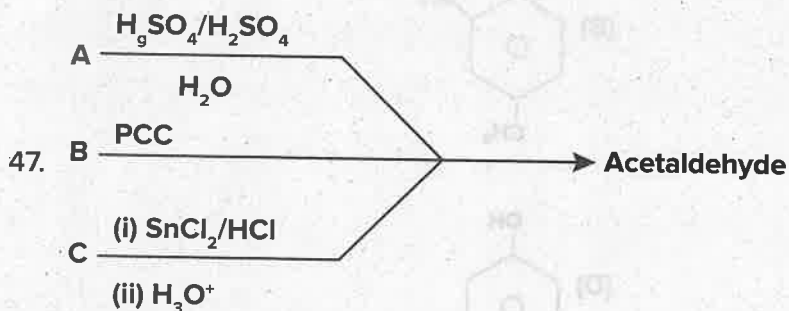

A, B and C respectively are

- (A) ethanol, ethane nitrile and ethyne
 (B) ethane nitrile, ethanol and ethyne
 (C) ethyne, ethanol and ethane nitrile
 (D) ethyne, ethane nitrile and ethanol

48. The reagent which can do the conversion $CH_3COOH \longrightarrow CH_3 - CH_2 - OH$ is

- (A) $LiAlH_4$ / ether (B) H_2 , Pt
 (C) $NaBH_4$ (D) Na and C_2H_5OH

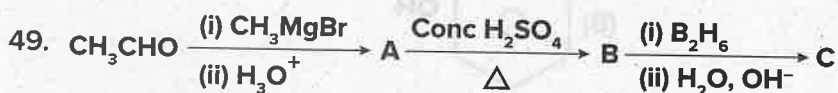

A and C are

- (A) Identical
 (B) Position isomers
 (C) Functional isomers
 (D) Optical isomers

SPACE FOR ROUGH WORK

46. H_2SO_3 , HNO_2 , CH_3COOH ಮತ್ತು HCN ಆಮ್ಲಗಳಿಗೆ K_a ಬೆಲೆಯು 1.3×10^{-2} , 4×10^{-4} , 1.8×10^{-5} ಮತ್ತು 4×10^{-10} ಆಗಿದೆ. ಈ ಮೇಲಿನ ಆಮ್ಲಗಳಲ್ಲಿ ಯಾವುದು ಪ್ರಬಲವಾದ ಸಹವರ್ತಿ ಪ್ರತ್ಯಾಮ್ಲವನ್ನು ಸೃಜಿಸುತ್ತದೆ?

(A) H_2SO_3

(B) HNO_2

(C) CH_3COOH

(D) HCN

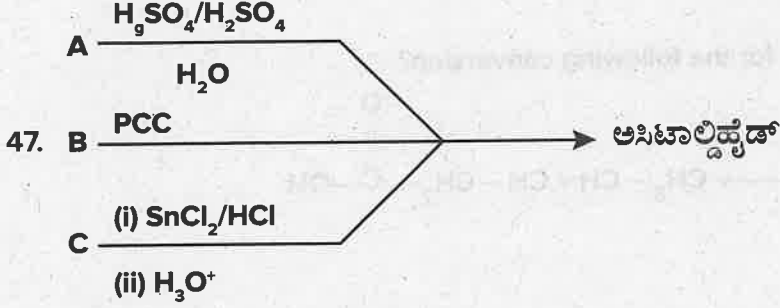

ಕ್ರಮವಾಗಿ A, B ಮತ್ತು C ಗಳು ಇವಾಗಿವೆ :

(A) ಎಥನಾಲ್, ಈಥೇನ್ ನೈಟ್ರೇಟ್ ಮತ್ತು ಈಥೇನ್

(B) ಈಥೇನ್ ನೈಟ್ರೇಟ್, ಎಥನಾಲ್ ಮತ್ತು ಈಥೇನ್

(C) ಈಥೇನ್ ಎಥನಾಲ್ ಮತ್ತು ಈಥೇನ್ ನೈಟ್ರೇಟ್

(D) ಈಥೇನ್, ಈಥೇನ್ ನೈಟ್ರೇಟ್ ಮತ್ತು ಎಥನಾಲ್

48. $CH_3COOH \longrightarrow CH_3 - CH_2 - OH$ ಈ ಪರಿವರ್ತನೆಯನ್ನು ಮಾಡುವ ಕಾರಕವು ಇದಾಗಿದೆ.

(A) $LiAlH_4$ / ಈಥರ್

(B) H_2 , Pt

(C) $NaBH_4$

(D) Na ಮತ್ತು C_2H_5OH

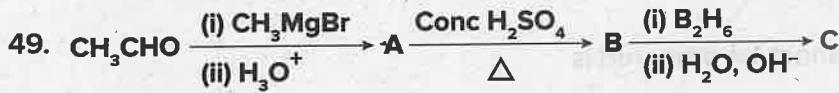

A ಮತ್ತು C ಗಳು

(A) ಒಂದೇ ಆಗಿವೆ

(B) ಸ್ಥಾನಿಕ ಸಮಾಂಗಿಗಳಾಗಿವೆ

(C) ಕ್ರಿಯಾ ಗುಂಪುಗಳ ಸಮಾಂಗಿಗಳಾಗಿವೆ

(D) ದ್ಯುತಿ ಸಮಾಂಗಿಗಳಾಗಿವೆ

SPACE FOR ROUGH WORK

50. Which of the following is not true for oxidation?

- (A) addition of oxygen
- (B) addition of electronegative element
- (C) removal of hydrogen
- (D) removal of electronegative element

51. Which is the most suitable reagent for the following conversion?

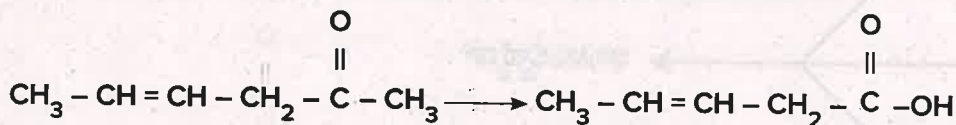

- (A) Tollen's reagent
- (B) Benzoyl peroxide
- (C) I_2 and NaOH solution with subsequent acidification
- (D) Sn and NaOH solution

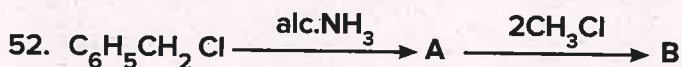

The product B is

- (A) N, N - Dimethyl phenyl methanamine
- (B) N, N - Dimethyl benzenamine
- (C) N - Benzyl - N - methyl methanamine
- (D) phenyl - N, N - dimethyl methanamine

53. The method by which aniline cannot be prepared is

- (A) Nitration of benzene followed by reduction with Sn and conc HCl
- (B) Degradation of benzamide with bromine in alkaline solution
- (C) Reduction of nitrobenzene with H_2 / Pd in ethanol
- (D) Potassium salt of phthalimide treated with chlorobenzene followed by the hydrolysis with aqueous NaOH solution

SPACE FOR ROUGH WORK

50. ಉತ್ಪರ್ಷಣಾ ಕ್ರಿಯೆಗೆ ಈ ಕೆಳಗಿನ ಯಾವುದು ಸರಿಯಲ್ಲ?

- (A) ಆಕ್ಸಿಜನ್‌ನ ಸೇರಿಸುವಿಕೆ
- (B) ವಿದ್ಯುದಣೀಯ ಧಾತುವಿನ ಸೇರಿಸುವಿಕೆ
- (C) ಹೈಡ್ರೋಜನ್‌ನ ತೆಗೆಯುವಿಕೆ
- (D) ವಿದ್ಯುದಣೀಯ ಧಾತುವಿನ ತೆಗೆಯುವಿಕೆ

51. ಈ ಪರಿವರ್ತನೆಗೆ ಅತ್ಯಂತ ಸೂಕ್ತವಾದ ಕಾರಕವು ಇದಾಗಿದೆ

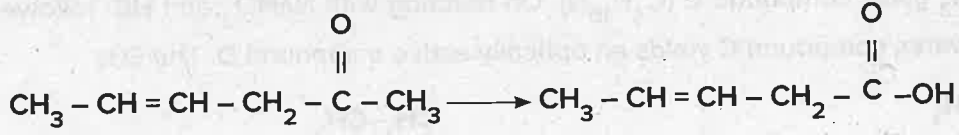

- (A) ಟಾಲನ್‌ನ ಕಾರಕ
- (B) ಬೆನ್‌ಜೋಯಲ್ ಪೆರಾಕ್ಸೈಡ್
- (C) I_2 ಮತ್ತು NaOH ದ್ರಾವಣ ಅದರ ನಂತರ ಆಮ್ಲೀಯಗೊಳಿಸುವಿಕೆ
- (D) Sn ಮತ್ತು NaOH ದ್ರಾವಣ

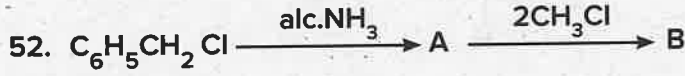

ಉತ್ಪನ್ನ B ಯು

- (A) N, N - ಡೈಮಿಥೈಲ್ ಫಿನ್ಯೆಲ್ ಮಿಥೇನಮೈನ್
- (B) N, N ಡೈಮಿಥೈಲ್ ಬೆಂಜೀನಮೈನ್
- (C) N-ಬೆಂಜೈಲ್-N-ಮಿಥೈಲ್ ಮಿಥೇನಮೈನ್
- (D) ಫಿನ್ಯೆಲ್ -N, N-ಡೈಮಿಥೈಲ್ ಮಿಥೇನಮೈನ್

53. ಯಾವ ವಿಧಾನದಿಂದ ಅನಿಲಿನ್‌ನ್ನು ತಯಾರು ಮಾಡಲು ಸಾಧ್ಯವಿಲ್ಲ

- (A) ಬೆನ್‌ಜೀನ್‌ನ ನೈಟ್ರೇಷನ್ ಅದರ ನಂತರ Sn ಮತ್ತು ಪ್ರಬಲ HCl ನಿಂದ ಅಪಕರ್ಷಣ ಕ್ರಿಯೆಯಿಂದ
- (B) ಬ್ರೊಮಿನ್ ಮಿಶ್ರಿತ ಪ್ರತ್ಯಾಮ್ಲಿಯ ದ್ರಾವಣದಲ್ಲಿ ಬೆಂಜಿಮೈಡ್‌ನ ನಿಮ್ನಕರಣ ಕ್ರಿಯೆಯಿಂದ
- (C) H_2 / Pd ಇರುವ ಇಥನಾಲ್ ನೊಂದಿಗೆ ನೈಟ್ರೊಬೆಂಜೀನನ್ನು ಅಪಕರ್ಷಿಸಿದಾಗ
- (D) ಕ್ಲೋರೋ ಬೆಂಜೀನ್‌ನ್ನು ಥ್ಯಾಲಿಮೈಡ್ ಸೋಡಿಯಂ ಲವಣದೊಂದಿಗೆ ವರ್ತಿಸಿ ನಂತರ ಜಲೀಯ NaOH ದ್ರಾವಣದಿಂದ ಜಲವಿಭಜನೆಗೊಳಿಸುವುದರಿಂದ

SPACE FOR ROUGH WORK

54. Permanent hardness cannot be removed by
- Using washing soda
 - Calgon's method
 - Clark's method
 - Ion exchange method
55. A hydrocarbon A (C_4H_8) on reaction with HCl gives a compound B (C_4H_9Cl) which on reaction with 1 mol of NH_3 gives compound C ($C_4H_{10}N$). On reacting with $NaNO_2$ and HCl followed by treatment with water, compound C yields an optically active compound D. The D is

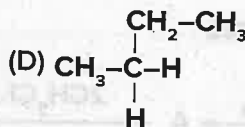
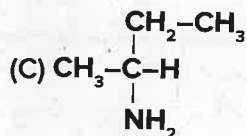
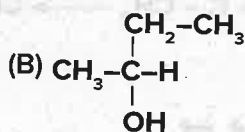
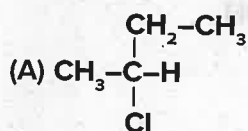

6. RNA and DNA are chiral molecules, their chirality is due to the presence of
- D-Sugar component
 - L-Sugar component
 - Chiral bases
 - Chiral phosphate ester unit
7. The property of the alkaline earth metals that increases with their atomic number is
- Ionisation enthalpy
 - Electronegativity
 - Solubility of their hydroxide in water
 - Solubility of their sulphate in water

SPACE FOR ROUGH WORK

54. ಶಾಶ್ವತ ಗಡಸುತನವನ್ನು ಇದರಿಂದ ನಿವಾರಿಸಲು ಆಗುವುದಿಲ್ಲ

(A) ವಾಷಿಂಗ್ ಸೋಡಾವನ್ನು ಬಳಸುವುದರಿಂದ

(B) ಕ್ಯಾಲ್ಸಿಯಂನ ವಿಧಾನದಿಂದ

(C) ಕ್ಲಾರ್ಕ್ ನ ವಿಧಾನ

(D) ಅಯಾನು ವಿನಿಮಯ ವಿಧಾನ

55. ಒಂದು ಹೈಡ್ರೋ ಕಾರ್ಬನ್ A (C_4H_8), HCl ನೊಂದಿಗೆ ವರ್ತಿಸಿ ಸಂಯುಕ್ತ B (C_4H_9Cl) ಕೊಡುತ್ತದೆ. ಇದು 1 mol ಅಮೋನಿಯಾದೊಂದಿಗೆ ವರ್ತಿಸಿ ಸಂಯುಕ್ತ C ($C_4H_{10}N$) ಕೊಡುತ್ತದೆ. ಇದು $NaNO_2$ ಮತ್ತು HCl ನೊಂದಿಗೆ ವರ್ತಿಸಿ ನಂತರ ನೀರಿನೊಂದಿಗೆ ವರ್ತಿಸಿದಾಗ ಸಂಯುಕ್ತ C ಯು ದ್ಯುತಿ ಪಟುತ್ವವಿರುವ ಸಂಯುಕ್ತ D ಕೊಡುತ್ತದೆ . ಸಂಯುಕ್ತ D ಯು

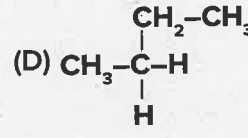
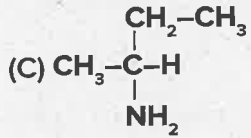
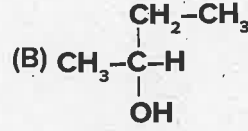
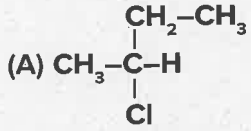

56. RNA ಮತ್ತು DNA ಕೈರಲ್ ಅಣುಗಳಾಗಿವೆ, ಅವುಗಳ ಕೈರಾಲಿಟಿಯು ಇದರಿಂದ ಉಂಟಾಗುವುದು

(A) D- ಸಕ್ಕರೆ ಅಂಶ

(B) L- ಸಕ್ಕರೆ ಅಂಶ

(C) ಕೈರಲ್ ಪ್ರತ್ಯಾಮ್ಲಗಳು

(D) ಕೈರಲ್ ಪಾಸ್ಫೇಟ್-ಎಸ್ಟರ್ ಅಂಶ

57. ಕ್ಷಾರ ಭಸ್ಮಲೋಹಗಳಲ್ಲಿ ಪರಮಾಣು ಸಂಖ್ಯೆಯೊಂದಿಗೆ ಹೆಚ್ಚಾಗುವ ಗುಣಗಳು ಇದಾಗಿದೆ

(A) ಅಯಾನೀಕರಣ ಎಂಥಾಲ್ಪಿ

(B) ವಿದ್ಯುದ್ದನೀಯತೆ

(C) ನೀರಿನಲ್ಲಿ ಅವುಗಳ ಹೈಡ್ರಾಕ್ಸೈಡ್ ವಿಲೀನತೆ

(D) ನೀರಿನಲ್ಲಿ ಅವುಗಳ ಸಲ್ಫೇಟ್‌ನ ವಿಲೀನತೆ

SPACE FOR ROUGH WORK

58. Primary structure in a nucleic acid chain contains bases as G A T G C The chain which is complementary to this chain is

(A) G G T G A

(B) T G A A G

(C) C T A C G

(D) T T T A G

59. In the detection of II group acid radical, the salt containing chloride is treated with concentrated sulphuric acid, the colourless gas is liberated. The name of the gas is

(A) Hydrogen chloride gas

(B) Chlorine gas

(C) Sulphur dioxide gas

(D) Hydrogen gas

60. The number of six membered and five membered rings in Buckminster Fullerene respectively is

(A) 20, 12

(B) 12, 20

(C) 14, 18

(D) 14, 11

SPACE FOR ROUGH WORK

58. ನ್ಯೂಕ್ಲಿಯಿಕ್ ಆಮ್ಲದ ಸರಪಳಿಯ ಪ್ರಾಥಮಿಕ ವಿನ್ಯಾಸದಲ್ಲಿ G A T G C ಪ್ರತ್ಯಾಮ್ಲಗಳಿವೆ. ಈ ಸರಪಳಿಗೆ ಪರಸ್ಪರ ಪೂರಕವಾದ ಸರಪಳಿಯು ಇದಾಗಿದೆ.
- (A) G G T G A (B) T G A A G
(C) C T A C G (D) T T T A G
59. ಎರಡನೇ ಗುಂಪಿನ ಆಮ್ಲೀಯ ರ್ಯಾಡಿಕಲ್‌ಗಳನ್ನು ಪತ್ತೆ ಮಾಡುವಾಗ ಕ್ಲೋರೈಡ್ ಹೊಂದಿರುವ ಲವಣವು ಸಾರಯುತ ಸಲ್ಫೂರಿಕ್ ಆಮ್ಲದೊಂದಿಗೆ ವರ್ತಿಸಿ ಬಣ್ಣ ರಹಿತ ಅನಿಲವು ಬಿಡುಗಡೆಯಾಗುತ್ತದೆ. ಅನಿಲದ ಹೆಸರು ಇದಾಗಿದೆ.
- (A) ಹೈಡ್ರೋಜನ್ ಕ್ಲೋರೈಡ್ ಅನಿಲ
(B) ಕ್ಲೋರಿನ್ ಅನಿಲ
(C) ಸಲ್ಫರ್ ಡೈ ಆಕ್ಸೈಡ್ ಅನಿಲ
(D) ಹೈಡ್ರೋಜನ್ ಅನಿಲ
60. ಬಕ್ ಮಿನ್‌ಸ್ಟರ್ ಪುಲ್ಲರಿನ್ ನಲ್ಲಿರುವ ಆರು ಸದಸ್ಯರ ಮತ್ತು ಐದು ಸದಸ್ಯರ ಉಂಗುರಗಳು ಕ್ರಮವಾಗಿ.
- (A) 20, 12 (B) 12, 20
(C) 14, 18 (D) 14, 11

SPACE FOR ROUGH WORK

SPACE FOR ROUGH WORK

(A) 1000

(B) 1000

(A) 1000

(B) 1000

(A) 1000

(B) 1000

(A) 1000

(B) 1000

SPACE FOR ROUGH WORK

KCET EXAMINATION – 2020
SUBJECT : CHEMISTRY

DATE :- 31-07-2020

TIME : 02.30 PM TO 03.50 PM

1. Copper is extracted from copper pyrites by
a) Thermal decomposition
b) Reduction by coke
c) Electrometallurgy
d) Auto reduction

Ans. d

2. Function of potassium ethyl xanthate in froth floatation process is to make the ore
a) Lighter
b) Hydrophobic
c) Hydrophilic
d) Heavier

Ans. b

3. Sulphide ore on roasting gives a gas X. X reacts with Cl_2 in the presence of activated charcoal to give Y. Y is:
a) SO_2Cl_2 b) S_2Cl_2 c) SCl_6 d) SOCl_2

Ans. a

4. Aqueous solution of a salt (A) forms a dense white precipitate with BaCl_2 solution. The precipitate dissolves in dilute HCl to produce a gas (B) which decolourises acidified KMnO_4 solution
A and B respectively are:
a) $\text{BaSO}_3, \text{SO}_2$ b) $\text{BaSO}_4, \text{H}_2\text{S}$
c) $\text{BaSO}_3, \text{H}_2\text{S}$ d) $\text{BaSO}_4, \text{SO}_2$

Ans. a

5. Bond angle in PH_4^+ is more than that of PH_3 . This is because
a) Lone pair – bond pair repulsion exists in PH_3
b) PH_4^+ has square planar structure
c) PH_3 has planar trigonal structure
d) Hybridisation of P changes when PH_3 is converted to PH_4^+

Ans. a

6. Incorrectly matched pair is:
a) XeO_3 – pyramidal
b) XeF_4 – tetrahedral
c) XeF_6 – distorted octahedral
d) XeOF_4 – square pyramidal

Ans. b

7. Phosphorus pentachloride
a) On hydrolysis gives an oxo acid of phosphorus which is tribasic
b) On hydrolysis gives an oxo acid of phosphorus which is a good reducing agent
c) Has all the five equivalent bonds
d) Exists as an ionic solid in which cation has octahedral structure and anion has tetrahedral structure

Ans. a

8. Identify the set of paramagnetic ions among the following:
a) $\text{V}^{2+}, \text{Co}^{2+}, \text{Ti}^{4+}$ b) $\text{Ni}^{2+}, \text{Cu}^{2+}, \text{Zn}^{2+}$
c) $\text{Ti}^{3+}, \text{Cu}^{2+}, \text{Mn}^{3+}$ d) $\text{Sc}^{3+}, \text{Ti}^{3+}, \text{V}^{3+}$

Ans. c

9. How many moles of acidified $\text{K}_2\text{Cr}_2\text{O}_7$ is required to liberate 6 moles of I_2 from an aqueous solution of I^- ?
a) 2 b) 1 c) 0.25 d) 0.5

Ans. a

10. Cu_2Cl_2 and CuCl_2 in aqueous medium
a) CuCl_2 is more stable than Cu_2Cl_2
b) Stability of Cu_2Cl_2 is equal to stability of CuCl_2
c) Both are unstable
d) Cu_2Cl_2 is more stable than CuCl_2

Ans. a

11. The Co-ordination number of Fe and Co in the complex ions, $[\text{Fe}(\text{C}_2\text{O}_4)_3]^{3-}$ and $[\text{Co}(\text{SCN})_4]^{2-}$ are respectively:
a) 3 and 4 b) 6 and 8
c) 4 and 6 d) 6 and 4

Ans. d

12. Number of stereoisomers exhibited by $[\text{Co}(\text{en})_2\text{Cl}_2]^+$ is
a) 4 b) 2 c) 5 d) 3

Ans. d

13. Give the IUPAC name of $[\text{Pt}(\text{NH}_3)_4][\text{PtCl}_4]$ is
- Tetra ammine platinum (o) tetra chlorido platinum (IV)
 - Tetra ammine palatinate (II) tetra chlorido platinum (II)
 - Tetra ammine palatinate (o) tetra chlorido platinum (IV)
 - Tetra ammine platinum (II) tetra chlorido palatinate (II)

Ans. d

14. Prolonged exposure of chloroform in humans may cause damage to liver. It is due to the formation of the following compound
- CCl_4
 - COCl_2
 - CH_2Cl_2
 - Cl_2

Ans. b

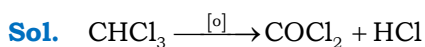

15. Which of the following halide shows highest reactivity towards $\text{S}_{\text{N}}1$ reaction?
- $\text{C}_6\text{H}_5\text{CH}_2\text{Cl}$
 - $\text{CH}_3 - \text{CH}_2\text{Cl}$
 - $\text{CH}_3 - \text{CH}_2 - \text{CH}_2 - \text{CH}_2\text{I}$
 - $\text{C}_6\text{H}_5\text{Cl}$

Ans. a

Sol. Rate of $\text{S}_{\text{N}}1$ reaction is directly proportional to stability of carbocation or Reactivity of $\text{S}_{\text{N}}1$ reaction is influenced by stability of carbocation.

16. In the reaction

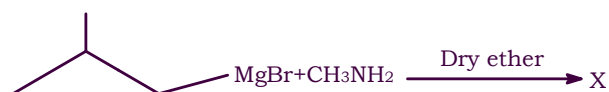

The number of possible isomers for the organic compound X is

- 4
- 5
- 3
- 2

Ans. d

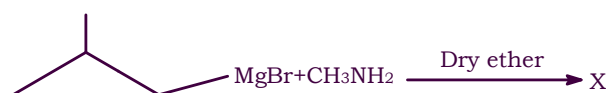

x = isobutane and it has two isomers.

17. Which of the following on heating gives an ether as major products?
- P: $\text{C}_6\text{H}_5\text{CH}_2\text{Br} + \text{CH}_3\text{ONa}$
 Q: $\text{C}_6\text{H}_5\text{ONa} + \text{CH}_3\text{Br}$
 R: $(\text{CH}_3)_3\text{C} - \text{Cl} + \text{CH}_3\text{ONa}$
 S: $\text{C}_6\text{H}_5\text{CH} = \text{CHCl} + \text{CH}_3\text{ONa}$

- Both R and S
- Both P and R
- Both Q and S
- Both P and Q

Ans. d

Sol. Primary alkyl halides/benzyl halides reacts with alkoxide/phenoxide through $\text{S}_{\text{N}}2$ mechanism gives ethers.

Vinyl and aryl halides least reactive towards $\text{S}_{\text{N}}1$

18. The steps involved in the conversion of propan-2-ol to propan-1-ol are in the order
- Dehydration, addition of HBr, heating with aq. KOH
 - Heating with PCl_5 , heating with alc. KOH, acid catalysed addition of water
 - Heating with PCl_5 , heating with alc. KOH, hydroboration oxidation
 - Dehydration, addition of HBr in presence of peroxide, heating with alc. KOH

Ans. c

19. Which of the following is the strongest base?
- CH_3COO^-
 - Cl^-
 - OH^-
 - CH_3O^-

Ans. d

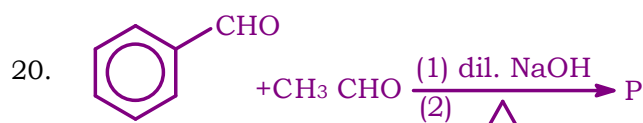

The product 'P' is

-
-
-
-

Ans. c

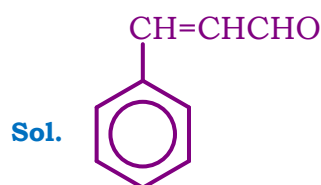

21. Which of the following has the lowest boiling point?
 a) $\text{CH}_3\text{CH}_2\text{OH}$ b) $\text{CH}_3 - \text{CH}_2 - \text{NH}_2$
 c) $\text{CH}_3 - \text{O} - \text{CH}_3$ d) HCOOH

Ans. c

22. The carbonyl compound that does not undergo aldol condensation is
 a) Acetone
 b) Di chloro acetaldehyde
 c) Tri chloro acetaldehyde
 d) Acetaldehyde

Ans. c

Sol. Aldehydes and ketones containing alpha hydrogens will undergo aldol condensation

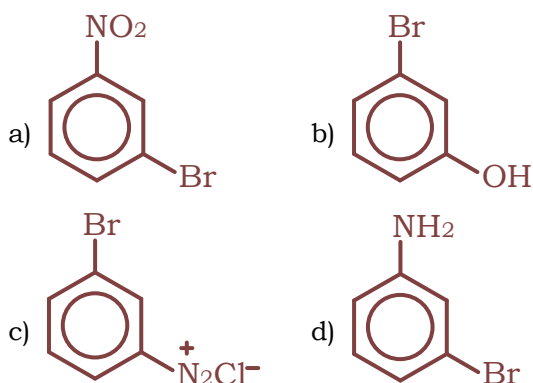
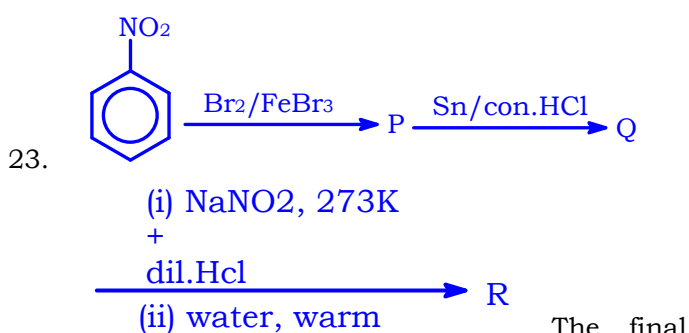

Ans. b

24. Hinsberg's reagent is
 a) $(\text{CH}_3\text{CO})_2\text{O}$ / pyridine
 b) $\text{C}_6\text{H}_5\text{SO}_2\text{Cl}$
 c) $\text{C}_6\text{H}_5\text{SO}_2\text{NH}_2$
 d) CH_3COCl / pyridine

Ans. b

25. Which one of the following vitamins is not stored in adipose tissue?
 a) A b) B_6 c) D d) E

Ans. b

26. Hypothyroidism is caused by the deficiency of
 a) Vitamin B-12 b) Adrenalin
 c) Thyroxine d) Glucocorticoid

Ans. c

27. $\text{C}_1\text{-C}_4$ glycosidic bond is NOT found in
 a) Maltose b) Sucrose
 c) Lactose d) Starch

Ans. b

28. Which of the following polymer has strongest intermolecular forces of attraction?
 a) Neoprene b) Terylene
 c) Polythene d) Polystyrene

Ans. b

29. Which of the following monomers can undergo condensation polymerization?
 a) Styrene b) Glycine
 c) Isoprene d) Propene

Ans. b

30. A food additive that acts as an antioxidant is
 a) BHA b) Saccharin
 c) Sugar syrup d) Salt

Ans. a

31. Which of the following is not related to drug-enzyme interaction?
 a) Allosteric site b) Antagonist
 c) Co-enzymes d) Enzyme inhibitor

Ans. b

32. 0.4 g of dihydrogen is made to react with 7.4 g of dichlorine to form hydrogen chloride. The volume of hydrogen formed at 273K and 1 bar pressure is
 a) 9.08L b) 4.54L c) 90.8L d) 45.4L

Ans. b

33. With regard to photoelectric effect, identify the correct statement among the following
 a) Energy of e^- ejected increases with the increase in the intensity of incident light
 b) Number of e^- ejected increases with the increase in the frequency of incident light
 c) Number of e^- ejected increases with the increase in work function
 d) Number of e^- ejected increases with the increase in the intensity of incident light

Ans. d

34. The last element of the p-block in 6th period is represented by the outer most electronic configuration

- a) $7s^2 7p^6$
 b) $5f^{14}6d^{10}7s^2 7p^5$
 c) $4f^{14}5d^{10}6s^2 6p^4$
 d) $4f^{14}5d^{10}6s^2 6p^6$

Ans. d

35. The conjugate base of NH_3 is

- a) NH_4^+ b) NH_4OH c) NH_2OH d) NH_2^-

Ans. d

36. A gas mixture contains 25% He and 75% CH_4 by volume at a given temperature and pressure. The percentage by mass of methane in the mixture is approximately_____

- a) 75% b) 25% c) 92% d) 8%

Ans. c

37. The percentage of s-character in the hybrid orbitals of nitrogen in NO_2^+ , NO_3^- and NH_4^+ respectively are

- a) 33.3%, 50%, 25% b) 33.3%, 25%, 50%
 c) 50%, 33.3%, 25% d) 25%, 50%, 33.3%

Ans. c

38. The formal charge on central oxygen atom in ozone is

- a) -1 b) 0 c) +2 d) +1

Ans. d

39. When the same quantity of heat is absorbed by a system at two different temperatures T_1 and T_2 , such that $T_1 > T_2$, change in entropies are ΔS_1 and ΔS_2 respectively. Then

- a) $\Delta S_1 < \Delta S_2$ b) $\Delta S_1 = \Delta S_2$
 c) $S_2 > S_1$ d) $\Delta S_2 < \Delta S_1$

Ans. a

Sol. $\Delta S = \frac{q}{T}$

q is same (constant)

$\therefore \Delta S \propto \frac{1}{T}$

40. The oxidation number of nitrogen atoms in NH_4NO_3 are

- a) +5, +5 b) -3, +5 c) +3, -5 d) -3, -3

Ans. b

41. A Lewis acid 'X' reacts with $LiAlH_4$ in ether medium to give a highly toxic gas. This gas when heated with NH_3 gives a compound commonly known as inorganic benzene. The gas is

- a) B_2O_3 b) B_2H_6 c) $B_3N_3H_6$ d) BF_3

Ans. b

42. The oxide of potassium that does not exist is

- a) K_2O b) KO_2 c) K_2O_2 d) K_2O_3

Ans. d

43. The metal that reacts with H_2 with both dil HCl and NaOH (aq) is

- a) Zn b) Mg c) Ca d) Fe

Ans. a

Sol. Amphoteric metals can react with both acids and bases.

44. Which of the following is NOT a pair of functional isomers?

- a) $C_2H_5OC_2H_5$ and $C_3H_7OCH_3$
 b) CH_3CH_2OH and CH_3OCH_3
 c) $CH_3CH_2NO_2$ and H_2NCH_2COOH
 d) CH_3COOH and $HCOOCH_3$

Ans. a

45. Identify 'X' in the following reaction

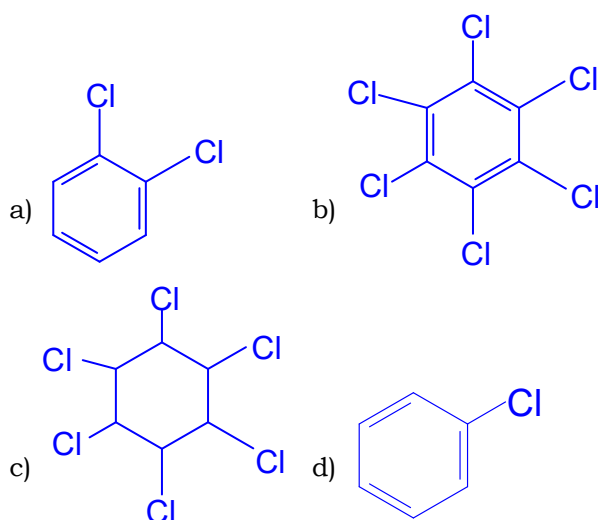
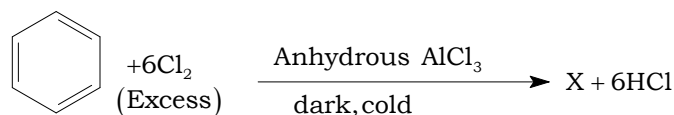

Ans. b

46. Which of the following is NOT a green house gas?

- a) CFC b) CO_2 c) O_2 d) NO_2

Ans. c

47. A metal exists as an oxide with formula $M_{0.96}O$. Metal M can exist as M^{+2} and M^{+3} in its oxide $M_{0.96}O$. The percentage of M^{+3} in the oxide is nearly
 a) 8.3% b) 4.6% c) 5% d) 9.6%

Ans. a

Sol. $M_{0.96}O$

No. of M^{+2} ions = x

No. of M^{+3} ions = $0.96 - x$

Total positive charges = Total negative charge (in magnitude)

$$x(2) + (0.96 - x)(3) = 1(2)$$

$$2x + 2.88 - 3x = 2$$

$$-x = 2 - 2.88$$

$$\therefore x = 0.88$$

$$\begin{aligned} \text{No. of } M^{+3} \text{ ions} &= 0.96 - 0.88 \\ &= 0.08 \end{aligned}$$

$$\begin{aligned} \text{Percentage of } M^{+3} &= \frac{0.08}{0.96} \times 100 \\ &= 8.33\% \end{aligned}$$

48. A metal crystallises in face centred cubic structure with metallic radius $\sqrt{2}A^\circ$. The volume of the unit cell (in m^3) is
 a) 4×10^{-10} b) 6.4×10^{-29}
 c) 4×10^{-9} d) 6.4×10^{-30}

Ans. b

Sol. For FCC

$$\text{Atomic radius}(r) = \frac{\sqrt{2}a}{4}$$

$$\sqrt{2} \times 10^{-10} = \frac{\sqrt{2}a}{4}$$

$$a = \frac{4 \times \sqrt{2} \times 10^{-10}}{\sqrt{2}}$$

$$a = 4 \times 10^{-10} \text{ m}$$

$$\begin{aligned} \text{Volume of unit cell} &= a^3 \\ &= (4 \times 10^{-10})^3 \\ &= 64 \times 10^{-30} \\ &= 6.4 \times 10^{-29} \text{ m}^3 \end{aligned}$$

49. Silicon doped with gallium forms
 a) n-type semiconductor
 b) both n and p type semiconductor
 c) an intrinsic semiconductor
 d) p-type semiconductor

Ans. d

50. The pair of electrolytes that possess same value for the constant (A) in the Debye - Huckel - Onsager equation, $\lambda_m = \lambda_m^\circ - A\sqrt{C}$ is
 a) $MgSO_4, NaSO_4$ b) $NH_4Cl, NaBr$
 c) $NaBr, MgSO_4$ d) $NaCl, CaCl_2$

Ans. b

51. Which of the following pair of solutions is isotonic?
 a) 0.01M $BaCl_2$ and 0.015M $NaCl$
 b) 0.001M $Al_2(SO_4)_3$ and 0.01 M $BaCl_2$
 c) 0.001M $CaCl_2$ and 0.001M $Al_2(SO_4)_3$
 d) 0.01M $BaCl_2$ and 0.001M $CaCl_2$

Ans. a

Sol. When solute particle concentration is same then they are isotonic

52. Solute 'X' dimerises in water to the extent of 80%. 2.5g of 'X' in 100g of water increases the boiling point by $0.3^\circ C$. The molar mass of 'X' is [$K_b = 0.52 K \text{ kg mol}^{-1}$]
 a) 13 b) 52 c) 65 d) 26

Ans. d

Sol. $i = 1 + \alpha \left(\frac{1}{n} - 1 \right)$

$$i = 1 + 0.8 \left(\frac{1}{2} - 1 \right)$$

$$i = 1 - 0.4 = 0.6$$

$$\Delta T_b = k_b \times \frac{W}{m} \times \frac{100}{W(\text{gm})} \times i$$

$$0.3 = 0.52 \times \frac{2.5}{m} \times \frac{1000}{100} \times 0.6$$

$$\begin{aligned} \text{Molar mass of } x(m) &= \frac{0.52 \times 2.5 \times 10 \times 0.6}{0.3} \\ &= 26 \end{aligned}$$

53. Given $E_{Fe^{+3}/Fe^{+2}}^\circ = +0.76V$ and $E_{I_2/I^-}^\circ = +0.55V$. The equilibrium constant for the reaction taking place in galvanic cell consisting of above two electrodes is $\left[\frac{2.303RT}{F} = 0.06 \right]$
 a) 1×10^7 b) 1×10^9 c) 3×10^8 d) 5×10^{12}

Ans. a

Sol. $E_{Fe^{+3}/Fe^{+2}}^\circ = +0.76$ (cathode)

$$E_{I_2/I^-}^\circ = +0.55 \text{ (Anode)}$$

$$\begin{aligned} E_{\text{cell}}^\circ &= E_C^\circ - E_A^\circ \\ &= 0.76 - 0.55 = 0.21 \end{aligned}$$

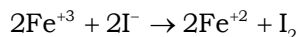

$$E_{\text{cell}}^0 = \frac{0.059}{n} \log k_c$$

$$0.21 = \frac{0.059}{2} \log k_c$$

$$\log k_c = 7$$

$$k_c = 10^7$$

54. If an aqueous solution of NaF is electrolyzed between inert electrodes, the product obtained at anode is

- a) F₂ b) H₂ c) Na d) O₂

Ans. d

55. In which of the following cases a chemical reaction is possible ?

- a) ZnSO_{4(aq)} is placed in a copper vessel
 b) AgNO₃ solution is stirred with a copper spoon
 c) Conc. HNO₃ is stored in a platinum vessel
 d) gold ornaments are washed with dil HCl

Ans. b

56. The time required for 60% completion of a first order reaction is 50 min. The time required for 93.6% completion of the same reaction will be

- a) 100 min b) 83.8 min
 c) 50 min d) 150 min

Ans. d

Sol. 60% completion

$$K = \frac{2.303}{t} \log \frac{[R_0]}{[R]}$$

$$K = \frac{2.303}{50} \log \frac{100}{40}$$

$$K = \frac{2.303}{50} \times 0.397$$

93.6% completion

$$K = \frac{2.303}{t} \log \frac{[R_0]}{[R]}$$

$$\frac{2.303}{50} \times 0.397 = \frac{2.303}{t} \log \frac{100}{6.4}$$

$$t = 150 \text{ min}$$

57. For an elementary reaction 2A+3B→ 4C+D the rate of appearance of C at time 't' is 2.8x10⁻³ mol L⁻¹S⁻¹. Rate of disappearance of B at 't' will be

a) $\frac{4}{3}(2.8 \times 10^{-3}) \text{ mol L}^{-1} \text{ S}^{-1}$

b) $\frac{3}{4}(2.8 \times 10^{-3}) \text{ mol L}^{-1} \text{ S}^{-1}$

c) $2(2.8 \times 10^{-3}) \text{ mol L}^{-1} \text{ S}^{-1}$

d) $\frac{1}{4}(2.8 \times 10^{-3}) \text{ mol L}^{-1} \text{ S}^{-1}$

Ans. b

Sol. $-\frac{1}{3} \frac{d(B)}{dt} = +\frac{1}{4} \frac{d(C)}{dt}$

$$\frac{-d(B)}{dt} = +\frac{3}{4} \frac{d(C)}{dt}$$

$$= \frac{+3}{4} (2.8 \times 10^{-3}) \text{ mol L}^{-1} \text{ S}^{-1}$$

58. The rate constant of a reaction is given by $k = P Z e^{-E_a/RT}$ under standard notation. In order to speed up the reaction, which of the following factors has to be decreased ?

- a) Z b) Both Z and T
 c) E_a d) T

Ans. c

59. A sol of AgI is prepared by mixing equal volumes of 0.1M AgNO₃ and 0.2M KI, which of the following statement is correct ?

- a) Sol obtained is a negative sol with NO₃⁻ adsorbed on AgI
 b) Sol obtained is a positive sol with Ag⁺ adsorbed on AgI
 c) Sol obtained is a positive sol with K⁺ adsorbed on AgI
 d) Sol obtained is a negative sol with I⁻ adsorbed on AgI

Ans. d

60. During Adsorption of a gas on a solid

- a) ΔG<0, ΔH<0, ΔS<0
 b) ΔG>0, ΔH>0, ΔS>0
 c) ΔG<0, ΔH<0, ΔS>0
 d) ΔG<0, ΔH>0, ΔS>0

Ans. a

DATE :- 29-08-2021

TIME : 10.30 AM TO 11.50 AM

1. For the reaction
 $A(g) + B(g) \rightleftharpoons C(g) + D(g); \Delta H = -QKJ$
 The equilibrium constant cannot be disturbed by
 a) Addition of A
 b) Addition of D
 c) Increasing of pressure
 d) Increasing of temperature

Ans. c

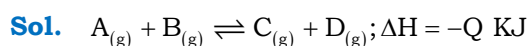

Pressure has no effect on equilibrium state if
 $\Delta n = 0$

2. An organic compound 'X' on treatment with PCC in dichloromethane gives the compound Y. Compound 'Y' reacts with I_2 and alkali to form yellow precipitate of triiodomethane. The compound X is
 a) CH_3CHO b) CH_3COCH_3
 c) CH_3CH_2OH d) CH_3COOH

Ans. c

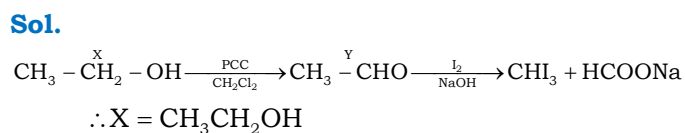

3. A compound 'A' (C_7H_8O) is insoluble in $NaHCO_3$ solution but dissolve in $NaOH$ and give a characteristic colour with neutral $FeCl_3$ solution. When treated with Bromine water compound 'A' forms the compound B with the formula $C_7H_5OBr_3$. 'A' is

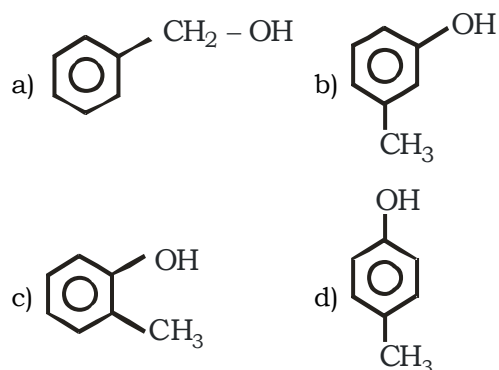

Ans. b

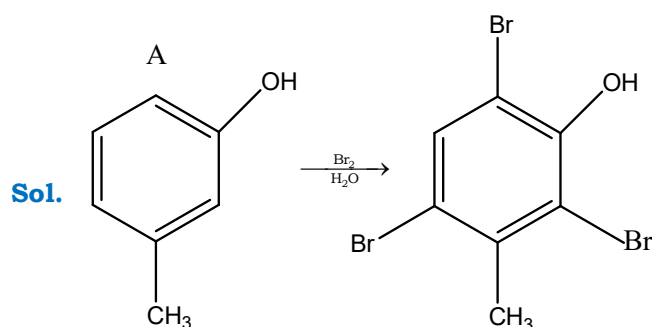

10. Which is the most suitable reagent for the following conversion ?

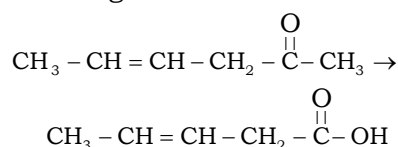

- a) Tollen's reagent
 b) Benzoyl peroxide
 c) I₂ and NaOH solution with subsequent acidification
 d) Sn and NaOH solution

Ans. c

Sol. Conceptual

11. $\text{C}_6\text{H}_5\text{CH}_2\text{Cl} \xrightarrow{\text{alc. NH}_3} \text{A} \xrightarrow{2\text{CH}_3\text{Cl}} \text{B}$. The product B is

- a) N, N-Dimethyl phenyl methanamine
 b) N, N-Dimethyl benzenamine
 c) N-Benzyl-N-methyl methanamine
 d) phenyl-N-N-dimethyl methanamine

Ans. a

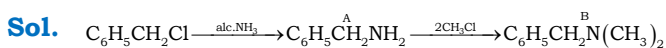

12. The method by which aniline cannot be prepared is

- a) Nitration of benzene followed by reduction with Sn and con. HCl
 b) Degradation of benzamide with bromine in alkaline solution
 c) Reduction of nitrobenzene with H₂/Pd in ethanol
 d) Potassium salt of phthalimide treated with chlorobenzene followed by the hydrolysis with aqueous NaOH solution

Ans. d

Sol. Conceptual

13. Permanent hardness cannot be removed by

- a) Using washing soda
 b) Calgon's method
 c) Clark's method
 d) Ion exchange method

Ans. c

Sol. Conceptual

14. A hydrocarbon A (C₄H₈) on reaction with HCl gives a compound B (C₄H₉Cl) which on reaction with 1 mol of NH₃ gives compound C (C₄H₁₀N). On reacting with NaNO₂ and HCl followed by treatment with water, compound C yields an optically active compound D. The is

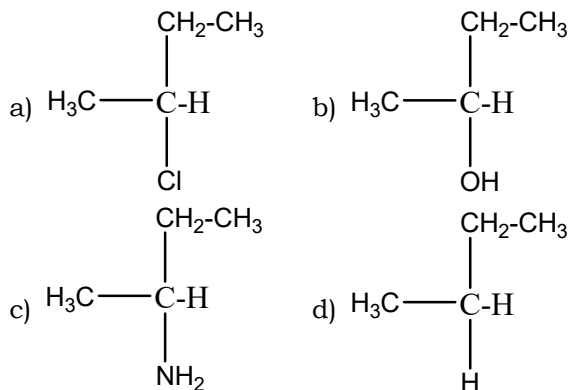

Ans. b

Sol. Optically active compound is option B.

15. RNA and DNA are chiral molecules, their chirality is due to the presence of

- a) D-sugar component
 b) L-sugar component
 c) Chiral bases
 d) Chiral phosphate ester unit

Ans. a

Sol. Conceptual

16. The property of the alkaline earth metals that increases with their atomic number is

- a) Ionisation enthalpy
 b) Electronegativity
 c) Solubility of their hydroxide in water
 d) Solubility of their sulphate in water

Ans. c

Sol. Conceptual

17. Primary structure in a nucleic acid contains bases as GATGC ... The chain which is complementary to this chain is

- a) G G T G A ... b) T G A A G ...
 c) C T A C G ... d) T T T A G ...

Ans. c

Sol. Conceptual

18. In the detection of II group acid radical, the salt containing chloride is treated with concentrated sulphuric acid, the colourless gas is liberated. The name of the gas is
- Hydrogen chloride gas
 - Chlorine gas
 - Sulphur dioxide gas
 - Hydrogen gas

Ans. a

Sol. Conceptual

19. The number of six membered and five membered rings in Buckminster Fullerene respectively is

a) 20, 12 b) 12, 20 c) 14, 18 d) 14, 11

Ans. a

Sol. Conceptual

20. In chrysoberyl, a compound containing Beryllium, Aluminium and oxygen, oxide ions form cubic close packed structure. Aluminium ions occupy $\frac{1}{4}$ th of octahedral voids. The

formula of the compound is

a) BeAlO_4 b) BeAl_2O_4 c) Be_2AlO_2 d) BeAlO_2

Ans. b

Be Al O N = No. of oxide ions involved in CCP

Sol. $\frac{N}{4} : \frac{2N}{4} : N \therefore \text{octahedral voids} = N$

1: 2: 4 Tetrahedral voids = 2N

21. The correct statement regarding defects in solid is

a) Frenkel defect is a vacancy defect
 b) Schottky defect is a dislocation defect
 c) Trapping of an electron in the lattice leads to the formation of F-centre
 d) Schottky defect has no effect on density

Ans. c

Sol. Frenkel defect – dislocation defect

Schottky defect – decreases density

F-centre – Trapping of on electrons in the lattices

22. A metal crystallises in BCC lattice with unit cell edge length of 300 pm and density 6.15gcm^{-3} . The molar mass of the metal is

a) 50g mol^{-1} b) 60g mol^{-1}
 c) 40g mol^{-1} d) 70g mol^{-1}

Ans. a

Sol. $d = \frac{ZM}{a^3 N_A}$

$$M = \frac{d a^3 N_A}{Z} = \frac{6.15 \times (300 \times 10^{-10})^3 \times 6 \times 10^{23}}{2} \cong 50\text{g mol}^{-1}$$

23. Henry's law constant for the solubility of N_2 gas in water at 298K is 1.0×10^5 atm. The mole fraction of N_2 in air is 0.8 The number of moles of N_2 from air dissolved in 10 moles of water at 298K and 5 atm pressure is

a) 4.0×10^{-4} b) 4.0×10^{-5}
 c) 5.0×10^{-4} d) 4.0×10^{-6}

Ans. a

Sol. $P_{\text{N}_2} = X_{\text{N}_2} \cdot P_{\text{total}}$
 $= 0.8 \times 5 = 4$ atm

$$P_{\text{N}_2} = K_H \cdot X_{\text{N}_2}$$

$$4 = 10^5 \cdot X_{\text{N}_2}$$

$$X_{\text{N}_2} = 4 \times 10^{-5}$$

$$X_{\text{N}_2} = \frac{n_{\text{N}_2}}{n_{\text{N}_2} + n_{\text{H}_2\text{O}}} \quad (n_{\text{N}_2} \llllll n_{\text{H}_2\text{O}})$$

$$4 \times 10^{-5} = \frac{n_{\text{N}_2}}{10}$$

$$n_{\text{N}_2} = 4 \times 10^{-4}$$

24. A pure compound contains 2.4g of C, 1.2×10^{23} atoms of H, 0.2 moles of oxygen atoms. Its empirical formula is

a) C_2HO b) $\text{C}_2\text{H}_2\text{O}_2$ c) CH_2O d) CHO

Ans. d

Sol. $2.4\text{g C} = \frac{2.4}{12} = 0.2\text{mol}$

$$1.2 \times 10^{23} \text{ atoms of H} = \frac{1.2 \times 10^{23}}{6 \times 10^{23}} = 0.2 \text{ mol}$$

0.2 mole of 'O' atoms

\therefore simplest ratio = C : H : O

$$0.2 : 0.2 : 0.2$$

$$= \text{CHO}$$

25. Choose the correct statement
- K_H value is same for a gas in any solution
 - Higher the K_H value more the solubility of gas
 - K_H value increases on increasing the temperature of the solution
 - Easily liquefiable gases usually has lesser K_H values

Ans. c

Sol. K_H value changes with solvent nature
Higher the K_H less is solubility
 K_H value increase with increase of 'T'
Easily liquefied gases have high K_H value

26. The K_H value (K bar) of Argon (I), Carbondioxide (II) formuldehyde (III) and methane (IV) are respectively 40.3, 167, 1.83×10^{-5} and 0.413 at 298 K. The increasing order of solubility of gas in liquid is
- I < II < IV < III
 - III < IV < II < I
 - I < III < II < IV
 - I < IV < II < III

Ans. a

Sol. $P_H = K_H \times$

$$K_H \propto \frac{1}{X(\text{solubility})}$$

\therefore more is the K_H less is the solubility

27. The vapour pressure of pure liquids A and B are 450 and 700 mm of Hg at 350 K respectively. If the total vapour pressure of the mixture is 600 mm of Hg, the composition of the mixture in the solution is
- $x_A = 0.4, x_B = 0.6$
 - $x_A = 0.6, x_B = 0.4$
 - $x_A = 0.3, x_B = 0.7$
 - $x_A = 0.7, x_B = 0.3$

Ans. a

Sol. $P_{\text{total}} = P_A^0 X_A + P_B^0 X_B$

$$= P_A^0 X_A + P_B^0 (1 - X_A)$$

$$600 = 450 X_A + 700(1 - X_A)$$

$$X_A = 0.4$$

$$X_B = 1 - 0.4 = 0.6$$

28. Consider the following electrodes

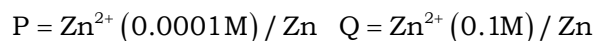

$E^\circ \text{Zn} / \text{Zn}^{2+} = -0.76\text{V}$ electrode potentials of the above electrodes in volts are in the order

- $P > S > R > Q$
- $S > R > Q > P$
- $Q > R > S > P$
- $P > Q > R > S$

Ans. c

Sol. $\text{Zn}^{2+}_{(\text{aq})} + 2e^- \rightarrow \text{Zn}_{(\text{s})}$

$$E_{\text{red}} = E_{\text{red}}^\ominus - \frac{0.059}{n} \log \frac{1}{[\text{Zn}^{2+}]}$$

$$E_{\text{red}} = -0.76 + \frac{0.059}{2} \log [\text{Zn}^{2+}]$$

$$\text{as } [\text{Zn}^{2+}] \uparrow E_{\text{red}} \uparrow$$

29. The number of angular and radial nodes in 3p orbital respectively are
- 3,1
 - 1,1
 - 2,1
 - 2,3

Ans. b

Sol. No. of angular nodes = $l = 1$ (3p)

$$\text{No. of radial nodes} = n - l - 1 = 3 - 1 - 1 = 1$$

30. The resistance of 0.01 m KCl solution at 298 K is 1500Ω . If the conductivity of 0.01 m KCl solution at 298 K is $0.1466 \times 10^{-3} \text{S cm}^{-1}$. The cell constant of the conductivity cell in cm^{-1} is

- 0.219
- 0.291
- 0.301
- 0.194

Ans. a

Sol. $G^* = KR$

$$= 0.146 \times 10^{-3} \times 1500$$

$$= 0.219$$

31. $\text{H}_{2(\text{g})} + 2\text{AgCl}_{(\text{s})} \rightleftharpoons 2\text{Ag}_{(\text{s})} + 2\text{HCl}_{(\text{aq})}$

E°_{cell} at 25°C for the cell is 0.22 V. The equilibrium constant at 25°C is

- 2.8×10^7
- 5.2×10^8
- 2.8×10^5
- 5.2×10^4

Ans. a

Sol. $\log K_c = \frac{E^\circ_{\text{cell}} \times n}{0.059} = \frac{0.22 \times 2}{0.059} = 7.45$

$$K_c = \text{Antilog}(7.45) = 2.8 \times 10^7$$

32. For a reaction $A + 2B \rightarrow \text{Products}$, when concentration of B alone is increased half life remains the same. If concentration of A alone is doubled, rate remains the same. The unit of rate constant for the reaction is

- a) S^{-1} b) $\text{L mol}^{-1} \text{S}^{-1}$
 c) $\text{mol L}^{-1} \text{S}^{-1}$ d) atm^{-1}

Ans. a

Sol. As $[B]$ increase, $t_{\frac{1}{2}}$ remains same

i.e. 1st order with respect to 'B'

$$\text{rate} = k[A]^0 [B]^1$$

overall order = 1

\therefore units of $k = \text{S}^{-1}$

33. The third ionisation enthalpy is highest in

- a) Alkali metals
 b) Alkaline earth metals
 c) Chalcogens
 d) Pnictogens

Ans. b

Sol. Conceptual

34. If the rate constant for a first order reaction is k , the time(t) required for the completion of 99% of the reaction is given by

- a) $t = \frac{4.606}{k}$ b) $t = \frac{2.303}{k}$
 c) $t = \frac{0.693}{k}$ d) $t = \frac{6.909}{k}$

Ans. a

Sol.
$$t = \frac{2.303}{k} \log \frac{[R]_0}{[R]}$$

$$= \frac{2.303}{k} \log \left(\frac{100}{1} \right)$$

$$= \frac{4.606}{k}$$

35. The rate of a gaseous reaction is given by the expression $k[A][B]^2$. If the volume of vessel is reduced to one half of the initial volume, the reaction rate as compared to original rate is

- a) $\frac{1}{16}$ b) $\frac{1}{8}$ c) 8 d) 16

Ans. c

Sol. rate = $K[A]^1 [B]^2$

$$= K \left[\frac{n}{v} \right]_A^1 \left[\frac{n}{v} \right]_B^2$$

$$= K \left[\frac{n}{\frac{v}{2}} \right]^1 \left[\frac{n}{\frac{v}{2}} \right]^2$$

$$= '8' K \left[\frac{n}{v} \right]^1 \left[\frac{n}{v} \right]^2$$

'8' times increases

36. The correct IUPAC name of

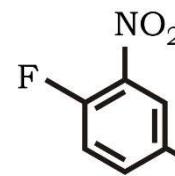

- a) 4-Ethyl-1-Fluoro-2-nitrobenzene
 b) 1-Ethyl-4-Fluoro-3-nitrobenzene
 c) 3-Ethyl-6-Fluoronitrobenzene
 d) 5-Ethyl-2-Fluoronitrobenzene

Ans. a

Sol. Conceptual

37. Higher order (>3) reactions are rare due to

- a) Shifting of equilibrium towards reactants due to elastic collisions
 b) Loss of active species on collision
 c) Low probability of simultaneous collision of all reacting species
 d) Increase in entropy as more molecules are involved

Ans. c

Sol. Conceptual

38. Arrange benzene, n-hexane and ethyne in decreasing order of their acidic behaviour

- a) Benzene > n-hexane > ethyne
 b) n-hexane > Benzene > ethyne
 c) ethyne > n-hexane > Benzene
 d) ethyne > Benzene > n-hexane

Ans. d

Sol. Conceptual

39. A colloidal solution is subjected to an electric field than colloidal particles move towards anode. The amount of electrolytes of BaCl_2 , AlCl_3 and NaCl required to coagulate the given colloid is in the order
- $\text{NaCl} > \text{BaCl}_2 > \text{AlCl}_3$
 - $\text{BaCl}_2 < \text{AlCl}_3 > \text{NaCl}$
 - $\text{AlCl}_3 = \text{NaCl} = \text{BaCl}_2$
 - $\text{AlCl}_3 > \text{BaCl}_2 > \text{NaCl}$

Ans. a

Sol. As ions are moving toward anode i.e. negatively charged colloid

$$\text{Coagulation value} \propto \frac{1}{\text{coagulating power}}$$

$$\therefore \text{Na}^{+1} > \text{Ba}^{+2} > \text{Al}^{+3}$$

40. Which of the following is an incorrect statement?
- Hydrogen bonding is stronger than dispersion forces
 - Sigma bonds are stronger than π -bonds
 - Ionic bonding is non-directional
 - σ -electrons are referred to as mobile electrons

Ans. d

Sol. Conceptual

41. Zeta potential is
- Potential required to bring about coagulation of a colloidal sol.
 - Potential required to give the particle a speed of 1 cm S^{-1}
 - Potential difference between fixed charged layer and the diffused layer having opposite charges
 - Potential energy of the colloidal particles.

Ans. c

Sol. Conceptual

42. Which of the following compound on heating gives N_2O ?
- $\text{Pb}(\text{NO}_3)_2$
 - NH_4NO_3
 - NH_4NO_2
 - NaNO_3

Ans. b

Sol. Conceptual

43. Which of the following property is true for the given sequence
 $\text{NH}_3 > \text{PH}_3 > \text{AsH}_3 > \text{SbH}_3 > \text{BiH}_3$?
- Reducing property
 - Thermal stability
 - Bond angle
 - Acidic character

Ans. b

Sol. Conceptual

44. The correct order of boiling point in the following compounds is
- $\text{HF} > \text{H}_2\text{O} > \text{NH}_3$
 - $\text{H}_2\text{O} > \text{HF} > \text{NH}_3$
 - $\text{NH}_3 > \text{H}_2\text{O} > \text{HF}$
 - $\text{NH}_3 > \text{HF} > \text{H}_2\text{O}$

Ans. b

Sol. Conceptual

45. XeF_6 on partial hydrolysis gives a compound X, which has square pyramidal geometry 'X' is
- XeO_3
 - XeO_4
 - XeOF_4
 - XeO_2F_2

Ans. c

Sol. $\text{XeF}_6 + \text{H}_2\text{O} \rightarrow \text{XeOF}_4 + 2\text{HF}$ (XeOF_4 - square pyramidal)

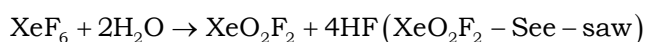

46. A colourless, neutral, paramagnetic oxide of Nitrogen 'P' on oxidation gives reddish brown gas Q. Q on cooling gives colourless gas R. R on reaction with P gives blue solid S. Identify P, Q, R, S respectively
- N_2O NO NO_2 N_2O_5
 - N_2O NO_2 N_2O_4 N_2O_3
 - NO NO_2 N_2O_4 N_2O_3
 - NO NON_2O_4 N_2O_5

Ans. c

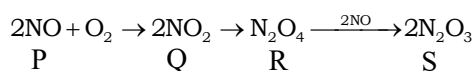

Sol.

47. Which of the following does not represent property stated against it?
- $\text{CO}^{+2} < \text{Fe}^{+2} < \text{Mn}^{+2}$ - Ionic size
 - $\text{Ti} < \text{V} < \text{Mn}$ - Number of oxidation states
 - $\text{Cr}^{+2} < \text{Mn}^{+2} < \text{Fe}^{+2}$ - Paramagnetic behaviour
 - $\text{Sc} > \text{Cr} > \text{Fe}$ - Density

Ans. c

Sol. Conceptual

48. Which one of the following is correct for all elements from Sc to Cu?
- The lowest oxidation state shown by them is +2
 - 4S orbital is completely filled in the ground state
 - 3d orbital is not completely filled in the ground state
 - The ions in +2 oxidation states are paramagnetic

Ans. d

Sol. Conceptual

49. When the absolute temperature of ideal gas is doubled and pressure is halved, the volume of gas
- will be half of original volume
 - will be 4 times the original volume
 - will be 2 times the original volume
 - will be $1/4^{\text{th}}$ times the original volume

Ans. b

Sol. $PV = nRT$

$$\frac{P_1 V_1}{T_1} = \frac{P_2 V_2}{T_2} \quad \frac{P \times V_1}{T} = \frac{P}{2} \times \frac{V_2}{2T} \quad V_2 = 4V_1$$

50. Which of the following pairs has both the ions coloured in aqueous solution? [Atomic numbers of [Sc = 21, Ti = 22, Ni = 28, Cu = 29, Mn = 25]
- Sc³⁺, Mn²⁺
 - Ni²⁺, Ti⁴⁺
 - Ti³⁺, Cu⁺
 - Mn²⁺, Ti³⁺

Ans. d

Sol. Conceptual

51. For the crystal field splitting in octahedral complexes,
- the energy of the e_g orbitals will decrease by $(3/5)\Delta_0$ and that of the t_{2g} will increase by $(2/5)\Delta_0$
 - the energy of the e_g orbitals will increase by $(3/5)\Delta_0$ and that of the t_{2g} will decrease by $(2/5)\Delta_0$
 - the energy of the e_g orbitals will increase by $(3/5)\Delta_0$ and that of the t_{2g} will increase by $(2/5)\Delta_0$
 - the energy of the e_g orbitals will decrease by $(3/5)\Delta_0$ and that of the t_{2g} will decrease by $(2/5)\Delta_0$

Ans. b

Sol. Conceptual

52. Peroxide effect is observed with the addition of HBr but not with the addition of HI to unsymmetrical alkene because
- H-I bond is stronger than H-Br and is not cleaved by the free radical
 - H-I bond is weaker than H-Br bond so that iodine free radicals combine to form iodine molecules
 - Bond strength of HI and HBr are same but free radicals are formed in HBr
 - All of these

Ans. b

Sol. Conceptual

53. The IUPAC name of $[\text{Co}(\text{NH}_3)_5(\text{CO}_3)]\text{Cl}$ is
- Pentaamminecarbonatocobalt (III) Chloride
 - Carbonatopentamminecobalt (III) Chloride
 - Pentaamminecarbonatocobaltate (III) Chloride
 - Pentaammine cobalt (III) Carbonate Chloride

Ans. a

Sol. Conceptual

54. Homoleptic complexes among the following are
- A) $\text{K}_3[\text{Al}(\text{C}_2\text{O}_4)_3]$, B) $[\text{CoCl}_2(\text{en})_2]^+$
- C) $\text{K}_2[\text{Zn}(\text{OH})_4]$
- A only
 - A and B only
 - A and C only
 - C only

Ans. c

Sol. Conceptual

55. The correct order for wavelengths of light absorbed in the complex ions $[\text{CoCl}(\text{NH}_3)_5]^{2+}$, $[\text{Co}(\text{NH}_3)_6]^{3+}$ and $[\text{Co}(\text{CN})_6]^{3-}$ is
- $[\text{CoCl}(\text{NH}_3)_5]^{2+} > [\text{Co}(\text{NH}_3)_6]^{3+} > [\text{Co}(\text{CN})_6]^{3-}$
 - $[\text{Co}(\text{NH}_3)_6]^{3+} > [\text{Co}(\text{CN})_6]^{3-} > [\text{CoCl}(\text{NH}_3)_5]^{2+}$
 - $[\text{Co}(\text{CN})_6]^{3-} > [\text{CoCl}(\text{NH}_3)_5]^{2+} > [\text{Co}(\text{NH}_3)_6]^{3+}$
 - $[\text{Co}(\text{NH}_3)_6]^{3+} > [\text{CoCl}(\text{NH}_3)_5]^{2+} > [\text{Co}(\text{CN})_6]^{3-}$

Ans. a

Sol. Wave length of light absorbed is inversely proportional to strength of the ligand.

**KCET – 2023 TEST PAPER WITH ANSWER KEY
(HELD ON SUNDAY 21ST MAY 2023)**

CHEMISTRY

1. Compounds P and R in the following reaction are

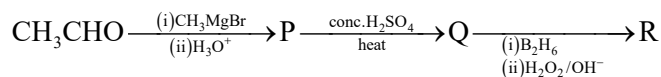

- (A) Metamers (B) Identical
(C) Position isomers (D) Functional isomers

Ans. C

2. Aniline does not undergo

- (A) Friedel-Craft reaction (B) Bromination
(C) Nitration (D) Sulphonation

Ans. A

3. The heating of phenyl methyl ether with HI produces an aromatic compound A which on treatment with con. HNO₃ gives B. A and B respectively are,

- (A) Iodobenzene, 1-Iodo-4-nitrobenzene (B) Phenol, Picric acid
(C) Methanol, Ethanoic acid (D) Picric acid, Phenol

Ans. B

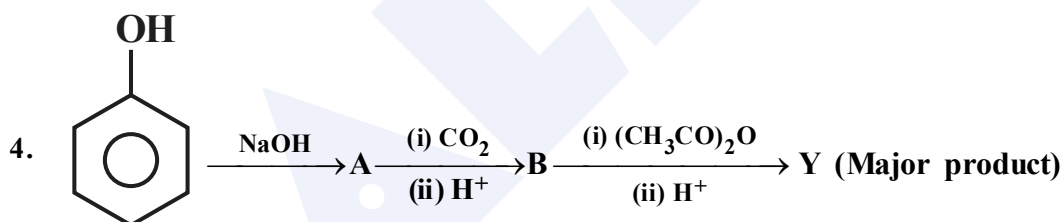

Y in the above reaction is

- (A) Cumene (B) Picric acid
(C) Salicylaldehyde (D) Aspirin

Ans. D

5. A better reagent to oxidize primary alcohols into aldehyde is :

- (A) Acidified K₂Cr₂O₇ (B) CrO₃
(C) PCC (D) Alkaline KMnO₄

Ans. C

6. In the reaction :

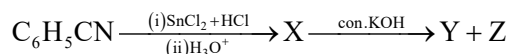

Formation of X, formation of Y and Z are known by

- (A) Wolff-Kishner reduction, Wurtz reaction. (B) Stephen reaction, Cannizaro reaction
(C) Rosenmund reduction, Cannizaro reaction (D) Clemmensen reduction, Sandmeyer reaction.

Ans. B

7. In the reaction :

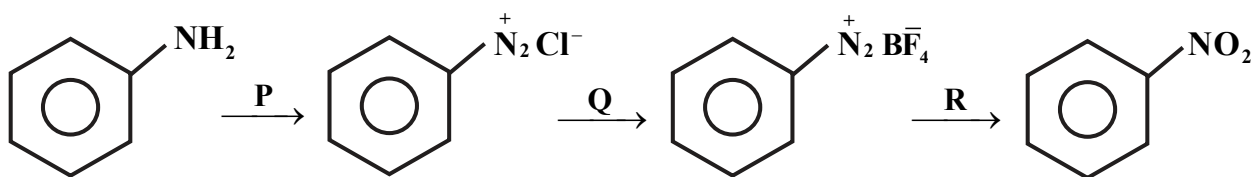

P, Q and R respectively are :

- (A) $\text{NaNO}_2 + \text{dil.HCl, BF}_3, \text{Cu} + \text{NaNO}_2$ (B) $\text{NaNO}_3 + \text{dil.HCl, F}_2, \text{Cu} + \text{NaNO}_3$
 (C) $\text{NaNO}_2 + \text{dil.HCl, HBF}_4, \text{Cu} + \text{NaNO}_2$ (D) $\text{NaNO}_2 + \text{con.HCl, F}_2, \text{Cu} + \text{NaNO}_3$

Ans. C

8. Thyroxine produced in the thyroid gland is an iodinated derivative of

- (A) Tyrosine (B) Tryptophan
 (C) Threonine (D) Lysine

Ans. A

9. Sucrose is dextrorotatory but after hydrolysis the mixture show laevorotation, this is because of

- (A) Recemic mixture is formed.
 (B) Laevorotation of fructose is more than dextrorotation of glucose.
 (C) Laevorotation of glucose is more than dextrorotation of fructose.
 (D) Sucrose is a non-reducing sugar

Ans. B

10. The correct order of match between column X and column Y is :

- | X | Y |
|----------------|-----------------------------------|
| I. Vitamin A | i. Muscular weakness |
| II. Vitamin D | ii. Increased blood clotting time |
| III. Vitamin E | iii. Night-blindness |
| IV. Vitamin K | iv. Osteomalacia |
- (A) I - iii, II - ii, III - iv, IV - i (B) I - iii, II - iv, III - i, IV - ii
 (C) I - iv, II - iii, III - ii, IV - i (D) I - ii, II - i, III - iii, IV - iv

Ans. B

11. Which of the following monomers form biodegradable polymers ?

- (A) Phenol and formaldehyde
 (B) 3-hydroxybutanoic acid and 3-hydroxypentanoic acid
 (C) Ethylene glycol and phthalic acid
 (D) Caprolactum and 1,3- Butadiene

Ans. B

12. Match the List-I with List-II in the following

List-I	List-II
1. Caprolactum	(a) $\left(\text{CH}_2 - \underset{\text{CH}_3}{\text{CH}} \right)_n$
2. Vinyl chloride	(b) $\left(\text{CH}_2 - \underset{\text{C}_6\text{H}_5}{\text{CH}} \right)_n$
3. Styrene	(c) $\left(\text{CH}_2 - \underset{\text{Cl}}{\text{CH}} \right)_n$
4. Propene	(d) $\left(\overset{\text{O}}{\parallel} \text{C}(\text{CH}_2)_3 \underset{\text{H}}{\text{N}} \right)_n$

- (A) 1-d,2-c, 3-a,4-b
(C) 1-c,2-d,3-a,4-b

- (B) 1-d,2-c, 3-b,4-a
(D) 1-a,2-d,3-c,4-b

Ans. B

13. Which one of the following is a non-narcotic analgesic ?

- (A) Aspirin (B) Morphine
(C) Heroin (D) Codeine

Ans. A

14. Receptors are proteins and crucial to body communication process. These receptors are embedded in

- (A) Endocrine gland (B) Chromosomes
(C) Cell membrane (D) Protein

Ans. C

15. A gas at a pressure of 2 atm is heated from 25 °C to 323 °C and simultaneously compressed to $\frac{2^{\text{rd}}}{3}$ of its original value. Then the final pressure is

- (A) 2 atm (B) 4 atm
(C) 1.33 atm (D) 6 atm

Ans. D

16. Lattice enthalpy for NaCl is + 788 kJ mol⁻¹ and $\Delta H_{\text{Hyd}}^{\circ} = -784 \text{ kJ mol}^{-1}$. Enthalpy of solution of NaCl is

- (A) -572 kJ mol⁻¹ (B) -4 kJ mol⁻¹
(C) + 572 kJ mol⁻¹ (D) +4 kJ mol⁻¹

Ans. D

17. At 500 K, for a reversible reaction $\text{A}_{2(\text{g})} + \text{B}_{2(\text{g})} \rightleftharpoons 2\text{AB}_{(\text{g})}$ in a closed container, $K_{\text{C}} = 2 \times 10^{-5}$. In the presence of catalyst, the equilibrium is attaining 10 times faster. The equilibrium constant K_{C} in the presence of catalyst at the same temperature is

- (A) 2×10^{-10} (B) 2×10^{-5}
(C) 2×10^{-4} (D) 2×10^{-6}

Ans. B

18. A weak acid with pK_a 5.9 and weak base with pK_b 5.8 are mixed in equal proportions pH of the resulting solution is

- (A) 7 (B) 7.05
(C) 7.005 (D) 7.5

Ans. B

19. Temperature of 25 °C in Fahrenheit and Kelvin scale respectively are

- (A) 45 °F and 260.15 K (B) 47 °F and 312.15 K
(C) 77 °F and 298.15 K (D) 17 °F and 298.15 K

Ans. C

20. The number of protons, neutrons and electrons in the ion ${}_{16}^{32}\text{S}^{2-}$ respectively are

- (A) 18, 16, 16 (B) 16, 16, 16
(C) 16, 18, 16 (D) 16, 16, 18

Ans. D

21. The correct order of first ionisation enthalpy of given elements is

- (A) C < B < Be < Li (B) Li < Be < B < C
(C) Li < B < Be < C (D) Be < Li < B < C

Ans. C

22. Which of the following statement is INCORRECT ?

- (A) Bond length of $\text{O}_2 <$ Bond length of O_2^{2-} (B) Bond order of $\text{O}_2 >$ Bond order of O_2^{2-}
(C) Bond length of $\text{O}_2 >$ Bond length of O_2^{2+} (D) Bond order of $\text{O}_2^+ <$ Bond order of O_2^{2-}

Ans. D

23. IUPAC name of the compound is

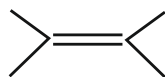

- (A) 1, 1, 2, 2 – tetra methylethene (B) 2, 3 – dimethyl butene
(C) 2, 3 – dimethylbut-2-ene (D) 2, 3 – dimethyl butyne

Ans. C

24. Among the following:

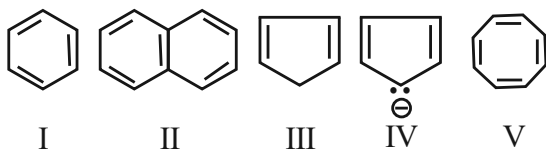

The set which represents aromatic species is

- (A) II and III (B) I, II and IV
(C) I, II and III (D) III, IV and V

Ans. B

25. Which one of the following gases converts haemoglobin into carboxy haemoglobin ?

- (A) NO (B) CO_2
(C) CO (D) O_2

Ans. C

26. What is the oxidation number of S in $H_2S_2O_8$?

- (A) +7 (B) +6
(C) +5 (D) +4

Ans. B

27. A 30% solution of hydrogen peroxide is

- (A) '50 volume' hydrogen peroxide (B) '100 volume' hydrogen peroxide
(C) '30 volume' hydrogen peroxide (D) '10 volume' hydrogen peroxide

Ans. B

28. A pair of amphoteric oxides is

- (A) BeO, MgO (B) BeO, ZnO
(C) Al_2O_3 , Li_2O (D) BeO, BO_3

Ans. B

29. The composition of water gas is

- (A) $CO_{(g)} + H_2O_{(g)}$ (B) $CO_{(g)} + H_{2(g)}$
(C) $CO_{(g)} + N_{2(g)}$ (D) $CH_{4(g)}$

Ans. B

30. The swelling in feet and ankles of an aged person due to sitting continuously for long hours during travel, is reduced by soaking the feet in warm salt water. This is because of:

- (A) Edema (B) Diffusion
(C) Reverse Osmosis (D) Osmosis

Ans. D

31. A sample of water is found to contain $5.85\% \left(\frac{w}{w}\right)$ of AB (molecular mass 58.5) and $9.50\% \left(\frac{w}{w}\right) XY_2$ (molecular mass 95). Assuming 80% ionisation of AB and 60% ionisation of XY_2 , the freezing point of water sample is

[Given : K_f for water $1.86 \text{ K kg mol}^{-1}$, Freezing point of pure water is 273 K and A, B and Y are monovalent ions]

- (A) 280.44 K (B) 281.75 K
(C) 264.25 K (D) 265.56 K

Ans. C

32. Match the column A (type of crystalline solid) with the column B (example for each type):

A		B	
P.	Molecular Solid	i.	SiC
Q.	Ionic Solid	ii.	Mg
R.	Metallic Solid	iii.	H_2O
S.	Network Solid	iv.	MgO

- (A) P - ii, Q - iv, R - iii, S - i (B) P - iii, Q - iv, R - ii, S - i
(C) P - iii, Q - i, R - ii, S - iv (D) P - iv, Q - iii, R - ii, S - i

Ans. B

33. A metal crystallises in a body centered cubic lattice with the metallic radius $\sqrt{3} \text{ \AA}$. The volume of the unit cell in m^3 is
- (A) 6.4×10^{-29} (B) 4×10^{-10}
 (C) 64×10^{-29} (D) 4×10^{-29}

Ans. A

34. If 'a' stands for the edge length of the cubic systems - The ratio of radii in simple cubic, body centered cubic and face centered cubic unit cells is
- (A) $\frac{1}{2}a : \frac{\sqrt{3}}{2}a : \frac{\sqrt{2}}{2}a$ (B) $\frac{1}{2}a : \sqrt{3}a : \frac{1}{\sqrt{2}}a$
 (C) $1a : \sqrt{3}a : \sqrt{2}a$ (D) $\frac{1}{2}a : \frac{\sqrt{3}}{4}a : \frac{1}{2\sqrt{2}}a$

Ans. D

35. Dimerisation of solute molecules in low dielectric constant solvent is due to :
- (A) Co-ordinate bond (B) Ionic bond
 (C) Hydrogen bond (D) Covalent bond

Ans. C

36. For a reaction, the value of rate constant at 300 K is $6.0 \times 10^5 \text{ s}^{-1}$. The value of Arrhenius factor A at infinitely high temperature is :
- (A) $\frac{6 \times 10^{-5}}{300}$ (B) 6×10^5
 (C) $6 \times 10^5 \times e^{-E_a/300R}$ (D) $e^{-E_a/300R}$

Ans. B

37. The rate constants k_1 and k_2 for two different reactions are $10^{16} \times e^{-2000/T}$ and $10^{15} \times e^{-1000/T}$ respectively. The temperature at which $k_1 = k_2$ is :
- (A) $\frac{1000}{2.303} \text{ K}$ (B) 1000 K
 (C) $\frac{2000}{2.303} \text{ K}$ (D) 2000 K

Ans. A

38. During the electrolysis of brine, by using inert electrodes,
- (A) Na deposits on cathode (B) Cl_2 liberates at anode
 (C) O_2 liberates at anode (D) H_2 liberates at anode

Ans. B

39. Consider the following 4 electrodes

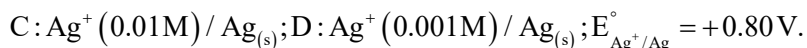
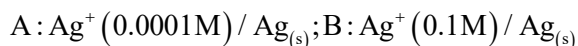

Then reduction potential in volts of the electrodes in the order

(A) $A > D > C > B$

(B) $A > B > C > D$

(C) $B > C > D > A$

(D) $C > D > A > B$

Ans. C

40. The resistance of 0.1 M weak acid HA in a conductivity cell is $2 \times 10^3 \text{ Ohm}$. The cell constant of the cell is 0.78 C m^{-1} and λ_m° of acid HA is $390 \text{ S cm}^2 \text{ mol}^{-1}$. The pH of the solution is

(A) 5

(B) 3

(C) 3.3

(D) 4.2

Ans. B

41. In which one of the following reactions, rate constant has the unit $\text{mol L}^{-1} \text{ s}^{-1}$.

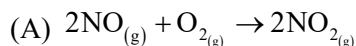

(B) Decomposition of HI on the surface of Gold

(C) Acid catalysed hydrolysis of $\text{CH}_3\text{COOCH}_3$

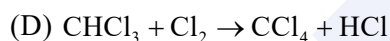

Ans. B

42. For the formation of which compound in Ellingham diagram ΔG° becomes more and more negative with increase in temperature ?

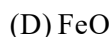
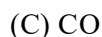
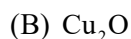
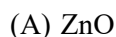

Ans. C

43. Which of the following compound does not give dinitrogen on heating ?

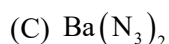

Ans. A

44. Aqueous solution of raw sugar when passed over beds of animal charcoal, it becomes colourless. Pick the correct set of terminologies that can be used for the above example.

	Adsorbent	Adsorbate	Process
(A)	Animal Charcoal	Colouring Substance	Adsorption
(B)	Colouring Substance	Animal Charcoal	Adsorption
(C)	Solution of Sugar	Animal Charcoal	Sorption
(D)	Animal Charcoal	Solution of Sugar	Absorption

Ans. A

45. For Freundlich adsorption isotherm, a graph of $\log(x/m)$ Vs. $\log(P)$ gives a straight line. The slope of line and its Y-axis intercept respectively are

- (A) $\log\left(\frac{1}{n}\right), \log K$ (B) $\frac{1}{n}, K$
 (C) $\log\left(\frac{1}{n}\right), K$ (D) $\frac{1}{n}, \log K$

Ans. D

46. When FeCl_3 is added to excess of hot water gives a sol 'X'. When FeCl_3 is added to $\text{NaOH}_{(\text{aq})}$ solution, gives sol 'Y'.

X and Y formed in the above processes respectively are

- (A) $\text{Fe}_2\text{O}_3 \cdot x\text{H}_2\text{O} / \text{Cl}^-$ and $\text{Fe}_2\text{O}_3 \cdot x\text{H}_2\text{O} / \text{OH}^-$ (B) $\text{Fe}_2\text{O}_3 \cdot x\text{H}_2\text{O} / \text{Fe}^{3+}$ and $\text{Fe}_2\text{O}_3 \cdot x\text{H}_2\text{O} / \text{OH}^-$
 (C) $\text{Fe}_2\text{O}_3 \cdot x\text{H}_2\text{O} / \text{OH}^-$ and $\text{Fe}_2\text{O}_3 \cdot x\text{H}_2\text{O} / \text{Fe}^{3+}$ (D) $\text{Fe}_2\text{O}_3 \cdot x\text{H}_2\text{O} / \text{H}^+$ and $\text{Fe}_2\text{O}_3 \cdot x\text{H}_2\text{O} / \text{Na}^+$

Ans. B

47. The reducing agent in the given equations :

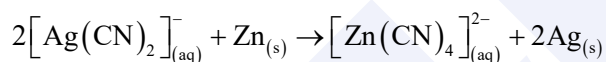
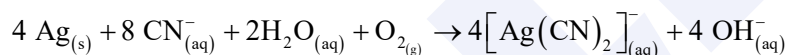

- (A) H_2O (B) CN^-
 (C) Zn (D) O_2

Ans. C

48. Which of the following is CORRECT with respect to melting point of a transition element?

- (A) $\text{Mn} > \text{Fe}$ (B) $\text{Ti} > \text{V}$
 (C) $\text{V} > \text{Cr}$ (D) $\text{Cr} > \text{Mn}$

Ans. D

49. $a\text{MnO}_4^- + b\text{S}_2\text{O}_3^{2-} + \text{H}_2\text{O} \rightarrow x\text{MnO}_2 + y\text{SO}_4^{2-} + z\text{OH}^-$ a and y respectively are

- (A) 3 ; 6 (B) 8 ; 8
 (C) 8 ; 3 (D) 8 ; 6

Ans. D

50. Which formula and name combination is INCORRECT?

- (A) $[\text{CoCl}_2(\text{en})_2]\text{Cl}$ - Dichloridodiethylenediammine cobalt (II) chloride
 (B) $[\text{Co}(\text{NH}_3)_4(\text{H}_2\text{O})\text{Cl}]\text{Cl}_2$ - Tetraammineaquachloridocobalt (III) chloride
 (C) $\text{K}_3[\text{Al}(\text{C}_2\text{O}_4)_3]$ - Potassium trioxalatoaluminate (III)
 (D) $[\text{Pt}(\text{NH}_3)_2\text{Cl}(\text{NO}_2)]$ - Diamminechloridonitrito - N - platinum (II)

Ans. A

51. Which of the following system in an octahedral complex has maximum unpaired electrons?

- (A) d^4 (low spin) (B) d^7 (high spin)
 (C) d^9 (high spin) (D) d^6 (low spin)

Ans. B

52. The correct decreasing order of basicity of hydrides of Group - 15 elements is

- (A) $\text{AsH}_3 > \text{SbH}_3 > \text{NH}_3 > \text{PH}_3$ (B) $\text{NH}_3 > \text{PH}_3 > \text{AsH}_3 > \text{SbH}_3$
 (C) $\text{SbH}_3 > \text{AsH}_3 > \text{PH}_3 > \text{NH}_3$ (D) $\text{PH}_3 > \text{AsH}_3 > \text{SbH}_3 > \text{NH}_3$

Ans. B

53. Which one of the following oxoacids of phosphorus can reduce AgNO_3 to metallic silver?

- (A) $\text{H}_4\text{P}_2\text{O}_6$ (B) H_3PO_4
 (C) H_3PO_2 (D) $\text{H}_4\text{P}_2\text{O}_7$

Ans. C

54. In solid state, PCl_5 is a/an

- (A) Ionic solid with $[\text{PCl}_4]^+$ and $[\text{PCl}_6]^-$ (B) Covalent solid present in the form of P_2Cl_{10}
 (C) Octahedral structure (D) Ionic solid with $[\text{PCl}_6]^+$ and $[\text{PCl}_4]^-$

Ans. A

55. In which one of the following pairs, both the elements does not have $(n-1)d^{10}ns^2$ configuration in its elementary state?

- (A) Hg, Cn (B) Cu, Zn
 (C) Zn, Cd (D) Cd, Hg

Ans. No Answer

56. $\text{CH}_3 - \text{CH} = \text{CH} - \text{CH}_2\text{OH} \xrightarrow{\text{PCC}} \text{CH}_3 - \text{CH} = \text{CH} - \text{CHO}$

Hybridisation change involved at C - 1 in the above reaction

- (A) sp^2 to sp^3 (B) sp to sp^2
 (C) sp^3 to sp (D) sp^3 to sp^2

Ans. D

57. If a didentate ligand ethane-1,2-diamine is progressively added in the molar ratio en : Ni :: 1:1, 2:1, 3:1 to

$[\text{Ni}(\text{H}_2\text{O})_6]^{2+}$ aq solution, following co-ordination entities are formed.

I. $[\text{Ni}(\text{H}_2\text{O})_4 \text{en}]^{2+}_{(\text{aq})}$ -pale blue

II. $[\text{Ni}(\text{H}_2\text{O})_2 (\text{en})_2]^{2+}_{(\text{aq})}$ -blue/purple

III. $[\text{Ni}(\text{en})_3]^{2+}_{(\text{aq})}$ -violet

The wavelength in nm of light absorbed in case of I and III are respectively

(A) 310 nm and 500 nm

(B) 600 nm and 535 nm

(C) 475 nm and 310 nm

(D) 300 nm and 475 nm

Ans. B

58. Which of the following is an organometallic compound?

(A) $(\text{CH}_3\text{COO})_2 \text{Ca}$

(B) CH_3ONa

(C) CH_3COONa

(D) $\text{CH}_3\text{CH}_2\text{MgBr}$

Ans. D

59. A pair of compounds having the same boiling points are

(A) Benzene and naphthalene

(B) (+) butan-2-ol and (-) butan-2-ol

(C) cis but-2-ene and trans but-2-ene

(D) n-hexane and neo-hexane

Ans. B

60. Identify A, B and C in the sequence:

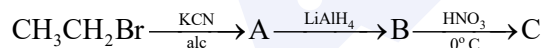

(A) $\text{CH}_3\text{CH}_2\text{CN}, \text{C}_2\text{H}_5\text{OH}, \text{C}_2\text{H}_5\text{N}_2\text{Cl}$

(B) $\text{CH}_3\text{CH}_2\text{CN}, \text{CH}_3\text{CH}_2\text{NH}_2, \text{C}_2\text{H}_5\text{OH}$

(C) $\text{CH}_3\text{CH}_2\text{CN}, \text{CH}_3\text{CH}_2\text{CH}_2\text{NH}_2, \text{CH}_3\text{CH}_2\text{CH}_2\text{OH}$

(D) $\text{CH}_3\text{CH}_2\text{NC}, \text{CH}_3\text{CH}_2\text{OH}, \text{CH}_3\text{CH}_2\text{CH}_2\text{NH}_2$

Ans. C

KCET 2025 Chemistry Question Paper

Time Allowed : 1 Hour 20 minutes

Maximum Marks : 180

Total Questions : 60

General Instructions

Read the following instructions very carefully and strictly follow them:

1. The test is of 1 hours 20 minutes duration.
2. The question paper consists of 60 questions. The maximum marks are 180.
3. There are in the question paper consisting of Physics, having 60 questions of equal weightage.

1. In the reaction between hydrogen sulphide and acidified permanganate solution,

- (1) H_2S is oxidised to SO_2 , MnO_4^- is reduced to MnO_2
 - (2) H_2S is reduced to SO_2 , MnO_4^- is oxidised to Mn^{2+}
 - (3) H_2S is oxidised to S , MnO_4^- is reduced to Mn^{2+}
 - (4) H_2S is reduced to S , MnO_4^- is oxidised to Mn^{2+}
-

2. A member of the Lanthanoid series which is well known to exhibit +4 oxidation state is

- (1) Europium
 - (2) Erbium
 - (3) Cerium
 - (4) Samarium
-

3. In which of the following pairs, both the elements do not have

$(n-1)d^{10}ns^2$ configuration?

- (1) Zn, Cd
 - (2) Cd, Hg
 - (3) Ag, Cu
 - (4) Cu, Zn
-

4. A ligand which has two different donor atoms and either of the two ligates with the central metal atom/ion in the complex is called

- (1) Unidentate ligand
 - (2) Polydentate ligand
 - (3) Ambidentate ligand
 - (4) Chelate ligand
-

5. Which of the following statements are true about $[\text{NiCl}_4]^{2-}$?

- (a) The complex has tetrahedral geometry.
- (b) Co-ordination number of Ni is 2 and oxidation state is +4.
- (c) The complex is sp^3 hybridised.

- (d) It is a high spin complex.
 (e) The complex is paramagnetic.
 (1) a, b, d and e
 (2) b, c, and d
 (3) a, b, c and d
 (4) a, c, d and e
-

6. Which formula and its name combination is incorrect?

- (1) $[CoCl_2(en)_2]Cl$, Dichloridobis (ethane-1, 2-diamine) cobalt(III) chloride
 (2) $[Co(NH_3)_5(CO_3)]Cl$, Pentaamine carbonylcobalt (III) chloride
 (3) $[Pt(NH_3)_2Cl(NO_2)]$, Diamine chloridonitrito-N-platinum(II)
 (4) $K_3[Cr(C_2O_4)_3]$, Potassium trioxalatochromate(III)
-

7. In the complex ion $[Fe(C_2O_4)_3]^{3-}$, the co-ordination number of Fe is

- (1) 5
 (2) 6
 (3) 3
 (4) 4
-

8. Match List-I with List-II for the following reaction pattern:

Glucose Reagent \rightarrow Product \rightarrow Structural prediction

List-I (Reagents)	List-II (Structural prediction)
a) Acetic anhydride	i) Glucose has an aldehyde group
b) Bromine water	ii) Glucose has a straight chain of six carbon atoms
c) Hydroiodic acid	iii) Glucose has five hydroxyl groups
d) Hydrogen cyanide	iv) Glucose has a carbonyl group

Choose the correct answer from the options given below.

- 1) a-iii, b-i, c-ii, d-iv 2) a-i, b-ii, c-iii, d-iv
 3) a-iii, b-ii, c-i, d-iv 4) a-iv, b-iii, c-ii, d-i
-

9. The correct sequence of α -amino acid, hormone, vitamin, carbohydrates respectively is

- (1) Glutamine, Insulin, Aspartic acid, Fructose
 - (2) Arginine, Testosterone, Glutamic acid, Maltose
 - (3) Aspartic acid, Insulin, Ascorbic acid, rhamnose
 - (4) Thiamine, Thyroxine, Vitamin A, Glucose
-

10. Which examples of carbohydrates exhibit α -link (α -glycosidic link) in their structure?

- (1) Amylose and Amylopectin
 - (2) Cellulose and Glycogen
 - (3) Glucose and Fructose
 - (4) Maltose and Lactose
-

11. In the titration of potassium permanganate (KMnO_4) against Ferrous ammonium sulphate (FAS) solution, dilute sulphuric acid but not nitric acid is used to maintain acidic medium, because

- (1) Nitric acid doesn't act as an indicator
 - (2) Nitric acid itself is an oxidising agent
 - (3) Nitric acid is a weak acid than sulphuric acid
 - (4) It is difficult to identify the end point
-

12. The group reagent NH_4Cl (s) and aqueous NH_3 , will precipitate which of the following ion

- (1) Al^{3+}
 - (2) Ba^{2+}
 - (3) Ca^{2+}
 - (4) NH_4^+
-

13. In the preparation of sodium fusion extract, the purpose of fusing organic compound with a piece of sodium metal is to

- (1) Convert the elements of the compound from covalent form to ionic form
 - (2) Convert the elements of the compound from ionic form to covalent form
 - (3) Decrease the melting point of the compound
 - (4) Convert the organic compound into vapour state
-

14. The sodium fusion extract is boiled with concentrated nitric acid while testing for halogens. By doing so, it

- (1) increases the solubility of AgCl
 - (2) increases the concentration of NO_3^- ion
 - (3) decomposes Na_2S and NaCN , if formed
 - (4) helps in precipitation of AgCl
-

15. Which of the following is not an aromatic compound?

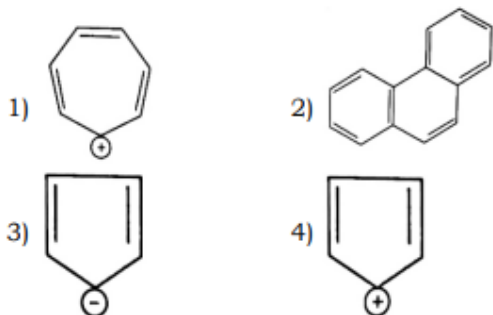

16. The IUPAC name of the given organic compound is $\text{HC} \equiv \text{C} - \text{CH} = \text{CH} - \text{CH}_2$.

- (1) Hexa - 5-yn-1,3-diene
 - (2) Hexa-1,3-dien-5-yne
 - (3) Hexa - 3,5-dien-1-yne
 - (4) Hexa-1-yn-3,5-diene
-

17. Among the following, identify the compound that is not an isomer of hexane:

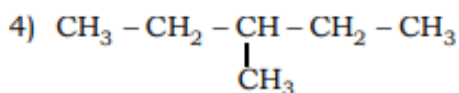
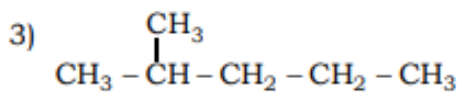
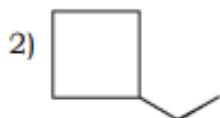
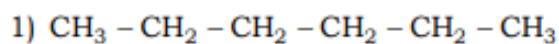

18. The organic compound can be classified as

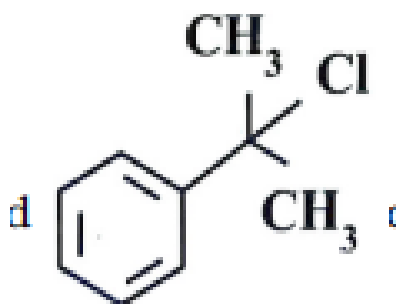

- (1) Benzyl halide
- (2) Aryl halide
- (3) Alkyl halide
- (4) Allylic halide

19. Chlorobenzene reacts with bromine gas in the presence of Anhydrous AlBr_3 to yield p-Bromochlorobenzene. This reaction is classified as.....

- (1) Nucleophilic substitution reaction
- (2) Electrophilic substitution reaction
- (3) Addition reaction
- (4) Elimination reaction

20. The organometallic compound $(\text{CH}_3)_3\text{CMgBr}$ on reaction with D_2O produces

- (1) $(\text{CD})\text{CD}$
- (2) $(\text{CD})\text{COD}$
- (3) $(\text{CH})\text{CD}$

(4) (CH)₃COD

21. The major product formed when 1 - Bromo-3-Chlorocyclobutane reacts with metallic sodium in dry ether is

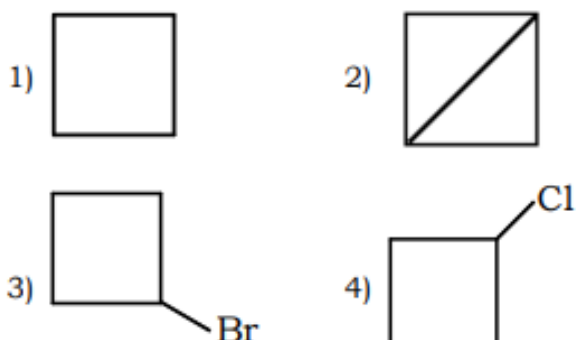

22. Ethyl alcohol is heated with concentrated sulphuric acid at 413 K (140°C). The major product formed is

- (1) CH - O - CH
 - (2) CH = CH
 - (3) CHCOOCH
 - (4) CH - O - CH
-

23. Phenol can be distinguished from propanol by using the reagent

- (1) Iron metal
 - (2) Iodine in alcohol
 - (3) Sodium metal
 - (4) Bromine water
-

24. Match the following with their pKa values

	Acid	pKa
I	Phenol	a) 16
II	p-Nitrophenol	b) 0.78
III	Ethyl alcohol.	c) 10
IV	Picric acid	d) 7.1

- 1) I - a, II - d, III - c, IV - b
- 2) I-a, II - b, III - c, IV - d
- 3) I-b, II - a, III - d, IV - c
- 4) I-c, II -d, III - a, IV - b

25.

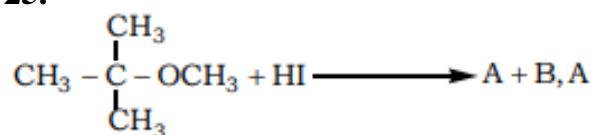

Respectively are

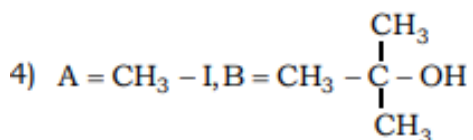
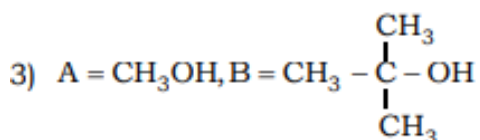
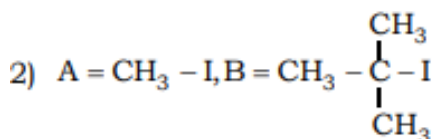
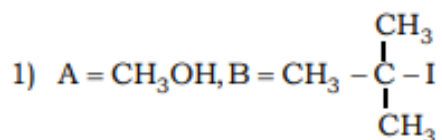

26. Oxidation of Toluene with chromyl chloride followed by hydrolysis gives Benzaldehyde. This reaction is known as

- (1) Kolbe reaction
- (2) Stephen reaction
- (3) Cannizzaro Reaction
- (4) Etard Reaction

27. Statement-I: Reduction of ester by DIBAL-H followed by hydrolysis gives aldehyde. Statement-II: Oxidation of benzyl alcohol with aqueous KMnO_4 leads to the formation of benzaldehyde.

Among the above statements, identify the correct statement.

- (1) Statement-I is true but statement-II is false
- (2) Statement-I is false but statement-II is true
- (3) Both statements-I and II are true

(4) Both statements-I and II are false

28. Arrange the following compounds in their decreasing order of reactivity towards nucleophilic addition reaction.

- (1) CHCOCH , CHCOCH , CHCHO
 - (2) $\text{CHCOCH} > \text{CHCOCH} > \text{CHCHO}$
 - (3) $\text{CHCHO} > \text{CHCOCH} > \text{CHCOCH}$
 - (4) $\text{CHCHO} > \text{CHCOCH} > \text{CHCOCH}$
-

29. Which of the following has the most acidic Hydrogen?

- (1) Dichloroacetic acid
 - (2) Trichloroacetic acid
 - (3) Chloroacetic acid
 - (4) Propanoic acid
-

30. Which of the following reagents are suitable to differentiate Aniline and N-methylaniline chemically?

- (1) Br water
 - (2) Conc. Hydrochloric acid and anhydrous zinc chloride
 - (3) Chloroform and Alcoholic potassium hydroxide
 - (4) Acetic anhydride
-

31. Which of the following reaction/s does not yield an amine?

- (I) $\text{R} - \text{X} + \text{NH} \xrightarrow{\text{alc}}$
 - (II) $\text{R} - \text{C} \equiv \text{N} \xrightarrow{\text{H/Ni}} \text{Na (Hg)/CHOH}$
 - (III) $\text{R} - \text{C} = \text{N} + \text{HO} \xrightarrow{\text{H}}$
 - (IV) $\text{R} - \text{C} - \text{NH} + 4 [\text{H}] \xrightarrow{\text{LiAlH}_4} \text{HO} + \text{H}$
-

32. Match the compounds given in List-I with the items given in List-II

List-I	List-II
(I) Benzenesulphonyl Chloride	(a) Zwitterion
(II) Sulphanilic acid	(b) Hinsberg reagent
(III) Alkyl Diazonium salts	(c) Dyes
(IV) Aryl Diazonium salts	(d) Conversion to alcohols

- 1) I-a, II-c, III-b, IV-d 2) I-c, II-a, III-d, IV-b
 3) I-b, II-a, III-d, IV-c 4) I-c, II-b, III-a, IV-d

33. The number of orbitals associated with 'N' shell of an atom is

- (1) 32
 (2) 3
 (3) 4
 (4) 16

34. According to the Heisenberg's Uncertainty principle, the value of $\Delta v \cdot \Delta x$ for an object whose mass is 10^{-6} kg is

- (1) $4.0 \times 10^{-26} \text{ ms}^{-1}$
 (2) $3.5 \times 10^{-25} \text{ ms}^{-1}$
 (3) $5.2 \times 10^{-29} \text{ ms}^{-1}$
 (4) $3.0 \times 10^{-24} \text{ ms}^{-1}$

35. Given below are two statements.

Statement-I: Adiabatic work done is positive when work is done on the system and internal energy of the system increases.

Statement-II: No work is done during free expansion of an ideal gas.

- (1) Statement-I is true but Statement-II is false.
 (2) Statement-I is false but Statement-II is true.
 (3) Both Statement-I and Statement-II are true.
 (4) Both Statement-I and Statement-II are false.

36. Which one of the following reactions has

$$\Delta H = \Delta U?$$

- (1) $C_6H_6(l) + \frac{15}{2}O_2(g) \rightarrow 6CO_2(g) + 3H_2O(l)$
(2) $2HI(g) \rightarrow H_2(g) + I_2(g)$
(3) $N_2(g) + 3H_2(g) \rightarrow 2NH_3(g)$
(4) $CaCO_3(s) \rightarrow CaO(s) + CO_2(g)$
-

37. Identify the incorrect statements among the following:

- (a) All enthalpies of fusion are positive.
(b) The magnitude of enthalpy change does not depend on the strength of the intermolecular interactions in the substance undergoing phase transformations.
(c) When a chemical reaction is reversed, the value of ΔH° is reversed in sign.
(d) The change in enthalpy is dependent on the path between initial state (reactants) and final state (products).
-

38. Which of the following statements is/are true about equilibrium?

- (a) Equilibrium is possible only in a closed system at a given temperature
(b) All the measurable properties of the system remain constant at equilibrium.
(c) Equilibrium constant for the reverse reaction is the inverse of the equilibrium constant for the reaction in the forward direction.
-

39. According to Le Chatelier's principle, in the reaction $CO(g) +$

$3H_2(g) \rightleftharpoons CH_4(g) + H_2O(g)$, the formation of methane is favoured by

- (a) increasing the concentration of CO
(b) increasing the concentration of H_2O
(c) decreasing the concentration of CH_4
(d) decreasing the concentration of H_2
-

40. The equilibrium constant at 298 K for the reaction $A + B \rightleftharpoons C + D$ is 100. If the initial concentrations of all the four species were 1 M each, then equilibrium concentration of D (in mol/L) will be

- (1) 1.818

- (2) 1.182
 - (3) 0.818
 - (4) 0.182
-

41. Among the following 0.1 m aqueous solutions, which one will exhibit the lowest boiling point elevation, assuming complete ionization of the compounds in solution?

- (1) Aluminium sulphate
 - (2) Potassium sulphate
 - (3) Sodium chloride
 - (4) Aluminium chloride
-

42. Variation of solubility with temperature T for a gas in liquid is shown by the following graphs. The correct representation is

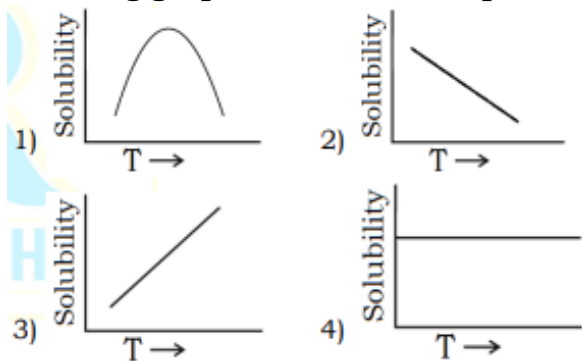

- (1) (2) (3) (4)
-

43. 180 g of glucose, $C_6H_{12}O_6$, is dissolved in 1 kg of water in a vessel. The temperature at which water boils at 1.013 bar is _____ for water is $0.52 \text{ K kg mol}^{-1}$). Boiling point for pure water is 373.15 K

- (1) 373.15 K
 - (2) 373.0 K
 - (3) 373.202 K
 - (4) 373.67 K
-

44. If N_2 gas is bubbled through water at 293 K, how many moles of N_2 gas would dissolve in 1 litre of water? Assume that N_2 exerts a partial pressure of 0.987 bar.

[Given K_H for N_2 at 293 K is 76.48 K bar]

- (1) 7.16×10^{-5}
 - (2) 7.16×10^{-4}
 - (3) 7.16×10^{-3}
 - (4) 0.716×10^{-3}
-

45. The correct statement/s about Galvanic cell is/are:

- (a) Current flows from cathode to anode
- (b) Anode is positive terminal
- (c) If $E_{\text{cell}} < 0$, then it is spontaneous reaction
- (d) Cathode is positive terminal

- (1) a, b, and c
 - (2) a, b, and c
 - (3) a, b, and c
 - (4) a and b only
-

46. The electronic conductance depends on:

- (1) The number of valence electrons per atom
 - (2) Concentration of the electrolyte
 - (3) Size of the ions
 - (4) Nature of electrolyte added
-

47. For a given half cell, $Al^{3+} + 3e^- \rightarrow Al$ on increasing the concentration of aluminium ion, the electrode potential will

- (1) No change
 - (2) First increase then decrease
 - (3) Increase
 - (4) Decrease
-

48. Match the following and select the correct option for the quantity of electricity, in $Cmol^{-1}$, required to deposit various metals at the cathode.

- (1) a) Ag^+ , ii) 386000 Cmol^{-1}
(2) b) Mg^{2+} , iii) 289500 Cmol^{-1}
(3) c) Al^{3+} , iv) 96500 Cmol^{-1}
(4) d) Ti^{4+} , i) 193000 Cmol^{-1}
-

49. Catalysts are used to increase the rate of a chemical reaction. Because it

- (1) Decrease the activation energy of the reaction
(2) Brings about improper orientation of reactant molecules
(3) Increases the potential energy barrier
(4) Increases the activation energy of the reaction
-

50. Half-life of a first order reaction is 20 seconds and initial concentration of reactant is 0.2M. The concentration of reactant left after 80 seconds is

- (1) 0.5 M
(2) 0.0125 M
(3) 0.2 M
(4) 0.1 M
-

51. In the given graph, E_a for the reverse reaction will be

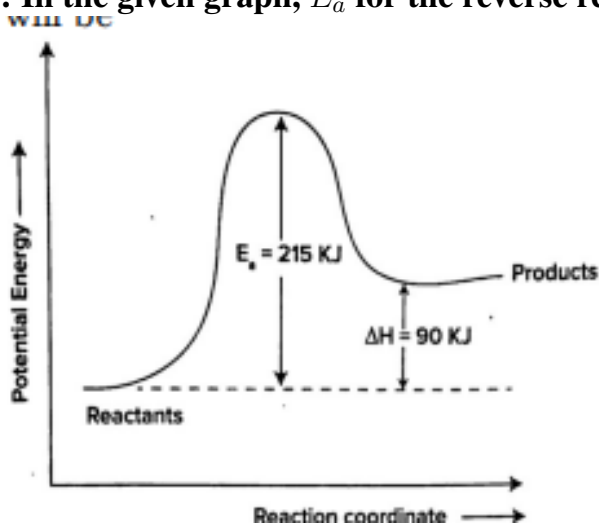

- (1) 215 KJ
(2) 90 KJ
(3) 305 KJ
(4) 125 KJ

52. For the reaction $2\text{N}_2\text{O}_5 \rightarrow 4\text{NO}_2(g) + \text{O}_2(g)$, the initial concentration of N_2O_5 is 2.0 mol L^{-1} , and after 300 minutes, it is reduced to 1.4 mol L^{-1} . The rate of production of NO_2 (in $\text{mol L}^{-1} \text{ min}^{-1}$) is

- (1) 4×10^{-4}
 - (2) 2.5×10^{-3}
 - (3) 4×10^{-3}
 - (4) 2.5×10^{-4}
-

53. Which of the following methods of expressing concentration are unitless?

- (1) Molality and Mole fraction
 - (2) Mass percent (W/W) and Molality
 - (3) Molality and Molality
 - (4) Mole fraction and Mass percent (W/W)
-

54. Select the INCORRECT statement/s from the following:

- (a) 22 books have infinite significant figures.
 - (b) In the answer of calculation 2.5×1.25 has four significant figures.
 - (c) Zero's preceding to first non-zero digit are significant.
 - (d) In the answer of calculation $12.11 + 18.0 + 1.012$ has three significant figures.
-

55. Given below are the atomic masses of the elements:

Element:	Li	Na	Cl	K	Ca	Br	Sr	I	Ba
Atomic Mass (gmol^{-1}):	7	23	35.5	39	40	80	88	127	137

Which of the following doesn't form triad?

- 1) Cl, Br, I
 - 2) Cl, K, Ca
 - 3) Li, Na, K
 - 4) Ba, Sr, Ca
-

56. The change in hybridisation (if any) of the 'Al' atom in the following reaction is



- (1) sp^2 to sp^3
 - (2) sp^3 to sp^d
 - (3) sp^3 to sp^2
 - (4) No change in the hybridisation state
-

57. Match List-I with List-II and select the correct option:

List-I (Molecule /ion)	List-II (Bond order)
(a) NO	(i) 1.5
(b) CO	(ii) 2.0
(c) O_2^-	(iii) 2.5
(d) O_2	(iv) 3.0

- 1) a-i, b-iv, c-iii, d-ii 2) a-ii, b-iii, c-iv, d-i
3) a-iv, b-iii, c-ii, d-i 4) a-iii, b-iv, c-i, d-ii
-

58. The electronic configuration of X and Y are given below:

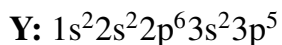
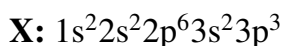

Which of the following is the correct molecular formula and type of bond formed between X and Y?

- 1) X_2Y_3 , coordinate bond
 - 2) X_3Y_3 , covalent bond
 - 3) X_2Y_3 , covalent bond
 - 4) X_3Y , ionic bond
-

59. Match List-I with List-II and choose the correct answer from the options given below.

List-I (Types of redox reactions)	List-II (Examples)
(a) Combination reaction	(i) $\text{Cl}_{2(g)} + 2\text{Br}^-_{(aq)} \rightarrow 2\text{Cl}^-_{(aq)} + \text{Br}_{2(l)}$
(b) Decomposition reaction	(ii) $2\text{H}_2\text{O}_{2(aq)} \rightarrow 2\text{H}_2\text{O}_{(l)} + \text{O}_{2(g)}$
(c) Displacement reaction	(iii) $\text{CH}_{4(g)} + 2\text{O}_{2(g)} \xrightarrow{\Delta} \text{CO}_{2(g)} + 2\text{H}_2\text{O}_{(l)}$
(d) Disproportionation Reaction	(iv) $2\text{H}_2\text{O}_{(l)} \xrightarrow{\Delta} 2\text{H}_{2(g)} + \text{O}_{2(g)}$

Choose the correct answer from the options given below.

- 1) a-ii, b-i, c-iv, d-iii 2) a-iii, b-iv, c-i, d-ii
 3) a-iii, b-ii, c-i, d-iv 4) a-iv, b-iii, c-i, d-ii

60. In the following pairs, the one in which both transition metal ions are colourless is

- 1) $\text{V}^{2+}, \text{Ti}^{3+}$
 2) $\text{Zn}^{2+}, \text{Mn}^{2+}$
 3) $\text{Ti}^{4+}, \text{Cu}^{2+}$
 4) $\text{Sc}^{3+}, \text{Zn}^{2+}$

CHEMISTRY

1. In Carbylamine test for primary amines the resulting foul smelling product is
 (A) CH_3NC (B) CH_3NCl_2 (C) COCl_2 (D) CH_3CN

2. Ethanoic acid undergoes Hell-Volhard Zelinsky reaction but Methanoic acid does not because of
 (A) absence of α -H atom in ethanoic acid
 (B) presence of α -H atom in methanoic acid
 (C) higher acidic strength of ethanoic acid than methanoic acid
 (D) presence of α -H atom in ethanoic acid

3. The general name of the compound formed by the reaction between aldehyde and alcohol is
 (A) Glycol (B) Ester (C) Acetate (D) Acetal

4. Reaction by which benzaldehyde can not be prepared is
 (A) Toluene $\xrightarrow[\text{(ii) } \text{H}_3\text{O}^+]{\text{(i) } \text{CrO}_2\text{Cl}_2 \text{ in } \text{CS}_2}$
 (B) Benzene + CO + HCl $\xrightarrow{\text{anhydrous } \text{AlCl}_3}$
 (C) Benzoyl chloride + $\text{H}_2 \xrightarrow[\Delta]{\text{Pd - BaSO}_4}$
 (D) Benzoic acid $\xrightarrow{\text{Zn-Hg and con. HCl}}$

5. The test to differentiate between pentan-2-one and pentan-3-one is
 (A) Fehling's test (B) Baeyer's test (C) Iodoform test (D) Benedict's test



6. A secondary amine is
- (A) a compound with an NH_2 group on the carbon atom in number 2 position
 - (B) an organic compound with two NH_2 group
 - (C) a compound in which 2 of the hydrogen of NH_3 have been replaced by organic groups
 - (D) a compound with two carbon atom and an NH_2 group
7. Which of the following is correctly matched ?
- (A) Bakelite – Novolac
 - (B) Nylon – acrylonitrile
 - (C) Polyester – tetrafluoroethene
 - (D) Teflon – copralactum
8. Which institute has approved the emergency use of 2-deoxy-D-Glucose as additive therapy for COVID-19 patients ?
- (A) Ministry of Health and Family Welfare
 - (B) Indian Council of Medical Research
 - (C) Drug Controller General of India
 - (D) World Health Organisation
9. A Nucleic acid, whether DNA or RNA gives on complete hydrolysis, two purine bases, two pyrimidine bases, a pentose sugar and phosphoric acid. Nucleotides which are intermediate products in the hydrolysis contain
- (A) purine or pyrimidine base and ortho-phosphoric acid
 - (B) purine or pyrimidine base and pentose sugar.
 - (C) Purine or pyrimidine base, a pentose sugar and ortho-phosphoric acid
 - (D) a purine base, pentose sugar and ortho-phosphoric acid

Space For Rough Work

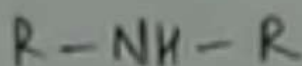
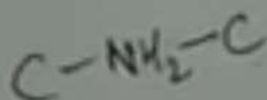

B-X

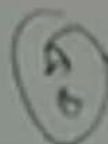

10. Which is most VISCOUS ?
 (A) Ethylene glycol (B) Methanol (C) Glycerol (D) Ethanol
11. The volume of 2.8 g of CO at 27 °C and 0.821 atm. pressure is ($R = 0.08210 \text{ lit. atm. K}^{-1} \text{ mol}^{-1}$)
 (A) 3 litres (B) 0.3 litres (C) 30 litres (D) 1.5 litres
12. The work done when 2 moles of an ideal gas expands reversibly and isothermally from a volume of 1 L to 10 L at 300 K is ($R = 0.0083 \text{ kJ K mol}^{-1}$)
 (A) 0.115 kJ (B) 11.5 kJ (C) 58.5 kJ (D) 5.8 kJ
13. An aqueous solution of alcohol contains 18 g of water and 414 g of ethyl alcohol. The mole fraction of water is
 (A) 0.7 (B) 0.1 (C) 0.9 (D) 0.4
14. If wavelength of photon is $2.2 \times 10^{-11} \text{ m}$ and $h = 6.6 \times 10^{-34} \text{ J s}$, then momentum of photon
 (A) $1.452 \times 10^{-44} \text{ kg m s}^{-1}$ (B) $3 \times 10^{-23} \text{ kg m s}^{-1}$
 (C) $6.89 \times 10^{-43} \text{ kg m s}^{-1}$ (D) $3.33 \times 10^{-22} \text{ kg m s}^{-1}$
15. Elements X, Y and Z have atomic numbers 19, 37 and 55 respectively. Which of the following statements is true about them ?
 (A) Z would have the highest ionization potential.
 (B) Their ionization potential would increase with increasing atomic number.
 (C) Y would have the highest ionization potential.
 (D) Y would have an ionization potential between those of X and Z.
16. In oxygen and carbon molecule the bonding is
 (A) $O_2 : 1\sigma, 1\pi ; C_2 : 0\sigma, 2\pi$ (B) $O_2 : 1\sigma, 1\pi ; C_2 : 1\sigma, 1\pi$
 (C) $O_2 : 0\sigma, 2\pi ; C_2 : 2\sigma, 0\pi$ (D) $O_2 : 2\sigma, 0\pi ; C_2 : 0\sigma, 2\pi$

Space For Rough Work

$$PV = nRT$$

(2 + 16)

17. Amphoteric oxide among the following :

- (A) Ag_2O (B) BcO (C) SnO_2 (D) CO_2

18. Which property of CO_2 makes it biologically and geo-chemically important ?

- (A) Its low solubility in water (B) Its acidic nature
(C) Its high compressibility (D) Its colourless and odourless nature

19. The IUPAC name for

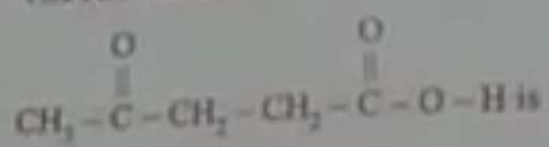

- (A) 1-carboxybutan-3-one (B) 1-hydroxy pentane-1, 4-dione
(C) 4-oxopentanoic acid (D) 1, 4-dioxopentanol

20. 1 mole of HI is heated in a closed container of capacity of 2 L. At equilibrium half a mole of HI is dissociated. The equilibrium constant of the reaction is

- (A) 0.25 (B) 1 (C) 0.35 (D) 0.5

21. Which among the following has highest pH ?

- (A) 1 M H_2SO_4 (B) 1 M HCl (C) 0.1 M $NaOH$ (D) 1 M $NaOH$

22. In which of the following compounds, an element exhibits two different oxidation states ?

- (A) N_2H_4 (B) NH_2CONH_2 (C) N_3H (D) NH_4NO_3

23. Which of the following hydrides is electron deficient ?

- (A) CH_4 (B) NaH (C) B_2H_6 (D) CaH_2

Space For Rough Work

D-1

$HI \rightleftharpoons \frac{1}{2} HI$
 2L
 1
 $K_c = \frac{[HI]^{1/2}}{[HI]}$

$-\overset{+}{N} = \overset{-}{N}$
 2C0617K2

28. Which of the following colligative properties can provide molar mass of proteins, polymers, and colloids with greater precision ?
- (A) Depression in freezing point
(B) Relative lowering of vapour pressure
(C) Osmotic pressure
(D) Elevation in boiling point
29. In Fuel cells _____ are used as catalysts.
- (A) Zinc - Mercury
(B) Platinum - Palladium
(C) Lead - Manganese
(D) Nickel - Cadmium
30. The molar conductivity is maximum for the solution of concentration
- (A) 0.005 M (B) 0.004 M (C) 0.001 M (D) 0.002 M
31. Alkali halides do not show dislocation defect because
- (A) Cations and anions have almost equal size.
(B) Cations and anions have low co-ordination number.
(C) There is large difference in size of cations and anions.
(D) Anions cannot be accommodated in vacant spaces.
32. Solubility of a gas in a liquid increases with
- (A) increase of P and decrease of T (B) increase of P and increase of T
(C) decrease of P and decrease of T (D) decrease of P and increase of T
33. The rise in boiling point of a solution containing 1.8 g of glucose in 100 g of solvent is 0.1 °C. The molal elevation constant of the liquid is
- (A) 2 K kg/mol (B) 0.1 K kg/mol (C) 10 K kg/mol (D) 1 K kg/mol
34. If 3 g of glucose (molar mass = 180 g) is dissolved in 60 g of water at 15 °C, the osmotic pressure of the solution will be
- (A) 6.57 atm (B) 0.34 atm (C) 5.57 atm (D) 0.65 atm



Space For Rough Work



35. A first order reaction is half completed in 45 min. How long does it need 99.9% of the reaction to be completed ?
 (A) 10 Hours (B) 5 Hours (C) 20 Hours (D) 7.5 Hours
36. The rate of the reaction :
 $\text{CH}_3\text{COOC}_2\text{H}_5 + \text{NaOH} \rightarrow \text{CH}_3\text{COONa} + \text{C}_2\text{H}_5\text{OH}$ is given by the equation,
 $\text{Rate} = K [\text{CH}_3\text{COOC}_2\text{H}_5] [\text{NaOH}]$. If concentration is expressed in mol L^{-1} , the unit of K is
 (A) $\text{L mol}^{-1} \text{s}^{-1}$ (B) $\text{mol}^{-2} \text{L}^2 \text{s}^{-1}$ (C) s^{-1} (D) $\text{mol L}^{-1} \text{s}^{-1}$
37. Colloidal solution commonly used in the treatment of skin disease is
 (A) Colloidal Gold (B) Colloidal Sulphur
 (C) Colloidal Antimony (D) Colloidal Silver
38. Specific conductance of 0.1 M HNO_3 is $6.3 \times 10^{-3} \text{ ohm}^{-1} \text{ cm}^{-1}$. The molar conductance of the solution is
 (A) $6.300 \text{ ohm}^{-1} \text{ cm}^2 \text{ mol}^{-1}$ (B) $630 \text{ ohm}^{-1} \text{ cm}^2 \text{ mol}^{-1}$
 (C) $63.0 \text{ ohm}^{-1} \text{ cm}^2 \text{ mol}^{-1}$ (D) $315 \text{ ohm}^{-1} \text{ cm}^2 \text{ mol}^{-1}$
39. For spontaneity of a cell, which is correct ?
 (A) $\Delta G = +ve, \Delta E = +ve$ (B) $\Delta G = 0, \Delta E = 0$
 (C) $\Delta G = -ve$ (D) $\Delta G = -ve, \Delta E = 0$
40. For n^{th} order of reaction, Half-life period is directly proportional to
 (A) a^{n-1} (B) $\frac{1}{a^{n-1}}$ (C) a^{1-n} (D) $\frac{1}{a^{1-n}}$
41. Half-life of a reaction is found to be inversely proportional to the fifth power of its initial concentration, the order of reaction is
 (A) 5 (B) 3 (C) 6 (D) 4

Space For Rough Work

$$t_{1/2} \propto \frac{1}{a^5}$$

$$\frac{6.3 \times 10^{-3}}{0.1}$$

$$6.3 \times 10^{-2}$$

24. Identify A and B in the reaction

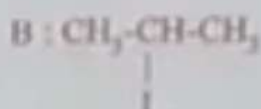
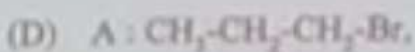
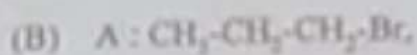
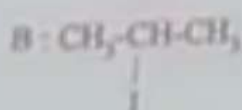
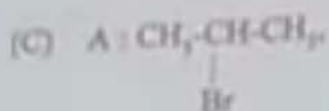
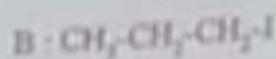
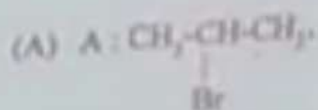
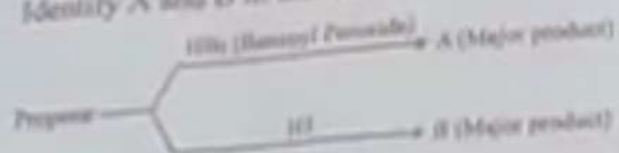

25. Vacant space in body centered cubic lattice unit cell is about

(A) 23%

(B) 32%

(C) 46%

(D) 10%

26. How many number of atoms are there in a cube based unit cell, having one atom on each corner and 2 atom on each body diagonal of cube ?

(A) 4

(B) 8

(C) 9

(D) 6

27. Which of the following is NOT true about the amorphous solids ?

(A) Amorphous solids can be moulded by heating.

(B) On heating they may become crystalline at certain temperature.

(C) They are anisotropic in nature.

(D) They may become crystalline on keeping for long time.

Space For Rough Work

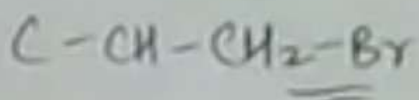
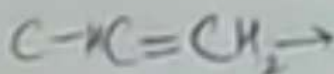

$8 \times \frac{1}{8} +$



28. Which of the following colligative properties can provide molar mass of proteins, polymers, and colloids with greater precision?
- (A) Depression in freezing point
(B) Relative lowering of vapour pressure
(C) Osmotic pressure
(D) Elevation in boiling point
29. In Fuel cells _____ are used as catalysts.
- (A) Zinc - Mercury
(B) Platinum - Palladium
(C) Lead - Manganese
(D) Nickel - Cadmium
30. The molar conductivity is maximum for the solution of concentration
- (A) 0.005 M
(B) 0.004 M
(C) 0.001 M
(D) 0.002 M
31. Alkali halides do not show dislocation defect because
- (A) Cations and anions have almost equal size.
(B) Cations and anions have low co-ordination number.
(C) There is large difference in size of cations and anions.
(D) Anions cannot be accommodated in vacant spaces.
32. Solubility of a gas in a liquid increases with
- (A) increase of P and decrease of T
(B) increase of P and increase of T
(C) decrease of P and decrease of T
(D) decrease of P and increase of T
33. The rise in boiling point of a solution containing 1.8 g of glucose in 100 g of solvent is 0.1°C . The molal elevation constant of the liquid is
- (A) 2 K kg/mol
(B) 0.1 K kg/mol
(C) 10 K kg/mol
(D) 1 K kg/mol
34. If 3 g of glucose (molar mass = 180 g) is dissolved in 60 g of water at 15°C , the osmotic pressure of the solution will be
- (A) 6.57 atm
(B) 0.34 atm
(C) 5.57 atm
(D) 0.65 atm



Space For Rough Work



35. A first order reaction is half completed in 45 min. How long does it need 99.9% of the reaction to be completed ?
 (A) 10 Hours (B) 5 Hours (C) 20 Hours (D) 7.5 Hours
36. The rate of the reaction :
 $\text{CH}_3\text{COOC}_2\text{H}_5 + \text{NaOH} \rightarrow \text{CH}_3\text{COONa} + \text{C}_2\text{H}_5\text{OH}$ is given by the equation,
 $\text{Rate} = K [\text{CH}_3\text{COOC}_2\text{H}_5] [\text{NaOH}]$. If concentration is expressed in mol L^{-1} , the unit of K is
 (A) $\text{L mol}^{-1} \text{s}^{-1}$ (B) $\text{mol}^{-2} \text{L}^2 \text{s}^{-1}$ (C) s^{-1} (D) $\text{mol L}^{-1} \text{s}^{-1}$
37. Colloidal solution commonly used in the treatment of skin disease is
 (A) Colloidal Gold (B) Colloidal Sulphur
 (C) Colloidal Antimony (D) Colloidal Silver
38. Specific conductance of 0.1 M HNO_3 is $6.3 \times 10^{-2} \text{ ohm}^{-1} \text{ cm}^{-1}$. The molar conductance of the solution is
 (A) $6300 \text{ ohm}^{-1} \text{ cm}^2 \text{ mol}^{-1}$ (B) $630 \text{ ohm}^{-1} \text{ cm}^2 \text{ mol}^{-1}$
 (C) $63.0 \text{ ohm}^{-1} \text{ cm}^2 \text{ mol}^{-1}$ (D) $315 \text{ ohm}^{-1} \text{ cm}^2 \text{ mol}^{-1}$
39. For spontaneity of a cell, which is correct ?
 (A) $\Delta G = +ve, \Delta E = +ve$ (B) $\Delta G = 0, \Delta E = 0$
 (C) $\Delta G = -ve$ (D) $\Delta G = -ve, \Delta E = 0$
40. For n^{th} order of reaction, Half-life period is directly proportional to
 (A) a^{n-1} (B) $\frac{1}{a^{n-1}}$ (C) a^{1-n} (D) $\frac{1}{a^{1-n}}$
41. Half-life of a reaction is found to be inversely proportional to the fifth power of its initial concentration, the order of reaction is
 (A) 5 (B) 3 (C) 6 (D) 4

Space For Rough Work

$$t_{1/2} \propto \frac{1}{a^5}$$

$$\frac{6.3 \times 10^{-2}}{0.1}$$

$$6.3 \times 10^{-1}$$



42. The strong reducing property of hypophosphorous acid is due to
 (A) two P-H bonds
 (B) its concentration
 (C) presence of phosphorus in its highest oxidation state
 (D) the positive valency of phosphorus
43. A transition metal exists in its highest oxidation state. It is expected to behave as
 (A) an oxidizing agent
 (B) a chelating agent
 (C) a reducing agent
 (D) a central metal in a co-ordination compound
44. What will be the value of x in Fe^{x+} , if the magnetic moment $\mu = \sqrt{24}$ BM ?
 (A) 0
 (B) +2
 (C) +1
 (D) +3
45. Which can adsorb larger volume of hydrogen gas ?
 (A) Finely divided platinum
 (B) Finely divided nickel
 (C) Colloidal $Fe(OH)_3$
 (D) Colloidal solution of palladium
46. The property of halogens which is not correctly matched is
 (A) $I > Br > Cl > F$ (density)
 (B) $F > Cl > Br > I$ (ionization enthalpy)
 (C) $F > Cl > Br > I$ (electron gain enthalpy)
 (D) $F > Cl > Br > I$ (electronegativity)
47. Which noble gas has least tendency to form compounds ?
 (A) Ar
 (B) He
 (C) Kr
 (D) Ne
48. $(NH_4)_2 Cr_2O_7$ on heating liberates a gas. The same gas will be obtained by
 (A) treating H_2O_2 with $NaNO_2$
 (B) heating NH_4NO_3
 (C) treating Mg_3N_2 with H_2O
 (D) heating NH_4NO_2



Space For Rough Work

$$\sqrt{24} \Rightarrow \sqrt{n(n+1)}$$

$$\sqrt{n^2+n}$$

55. The major product obtained when ethanol is heated with excess of conc. H_2SO_4 at 443 K is
(A) ethane (B) ethene (C) methane (D) ethyne

56. Among the following, the products formed by the reaction of anisole with HI are :
(A) Benzene + Methanol (B) Phenol + Iodomethane
(C) Phenol + Methane (D) Sodium phenate + Methanol

57. Which one of the following Chlorohydrocarbon readily undergoes solvolysis ?

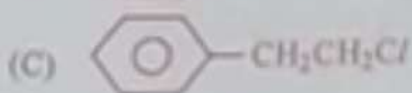
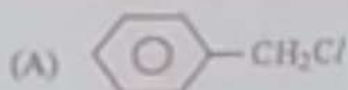

58. Identify the products A and B in the reactions :

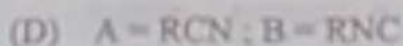
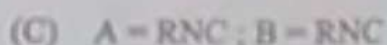
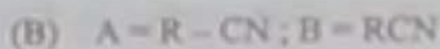
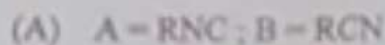
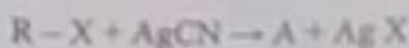

59. An organic compound with molecular formula C_7H_8O dissolves in NaOH and gives a characteristic colour with $FeCl_3$. On treatment with bromine, it gives a tribromo derivative $C_7H_5OBr_3$. The compound is

(A) m-Cresol (B) Benzyl alcohol (C) p-Cresol (D) o-Cresol

60. In Kolbes reaction the reacting substances are

(A) Sodium phenate and CCl_4

(B) Sodium phenate and CO_2

(C) Phenol and $CHCl_3$

(D) Phenol and CCl_4

Space For Rough Work

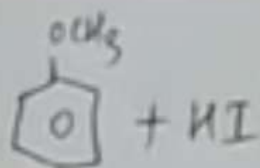

49. The complex hexamine platinum (IV) chloride will give _____ number of ions on ionization.
 (A) 3 (B) 5 (C) 2 (D) 4

50. In the following pairs of halogen compounds, which compound undergoes faster S_N1 reaction?

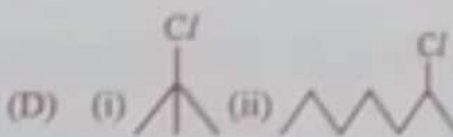
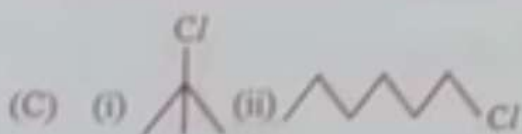
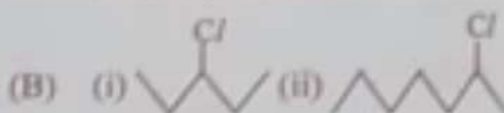
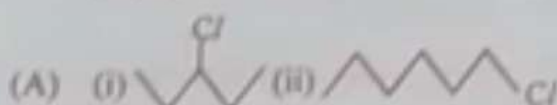
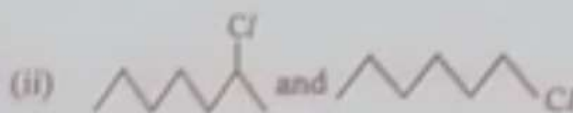
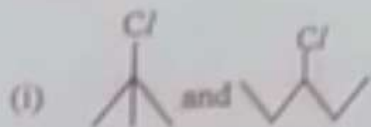

51. The only Lanthanoid which is radioactive

(A) Promethium (B) Lanthanum (C) Praseodymium (D) Cerium

52. All Cu(II) halides are known, except the iodide, the reason for it is that

- (A) Cu^{+2} has much more negative hydration enthalpy.
 (B) Iodide is bulky ion.
 (C) Cu^{+2} ion has smaller size.
 (D) Cu^{+2} oxidises iodide to iodine.

53. The correct IUPAC name of cis-platin is

- (A) diammine dichlorido platinum (0) (B) diammine dichlorido platinum (II)
 (C) dichlorido diammine platinum (IV) (D) diammine dichlorido platinum (IV)

54. Crystal Field Splitting Energy (CFSE) for $[CoCl_4]^{4-}$ is 18000 cm^{-1} . The Crystal Field Splitting Energy (CFSE) for $[CoCl_4]^{2-}$ will be

- (A) 8000 cm^{-1} (B) 18000 cm^{-1} (C) $10,000\text{ cm}^{-1}$ (D) 16000 cm^{-1}

Space For Rough Work

$(2\text{NH}_2\text{NH}_2)_2\text{Pt}$